

SAW Bandpass Filter F2G1G



Features

- RF bandpass filter
- No matching 50Ω single-ended operation
- Ceramic Surface Mounted Device Package (3.0 mm × 3.0 mm)
- RoHS Compliant

Package Dimension

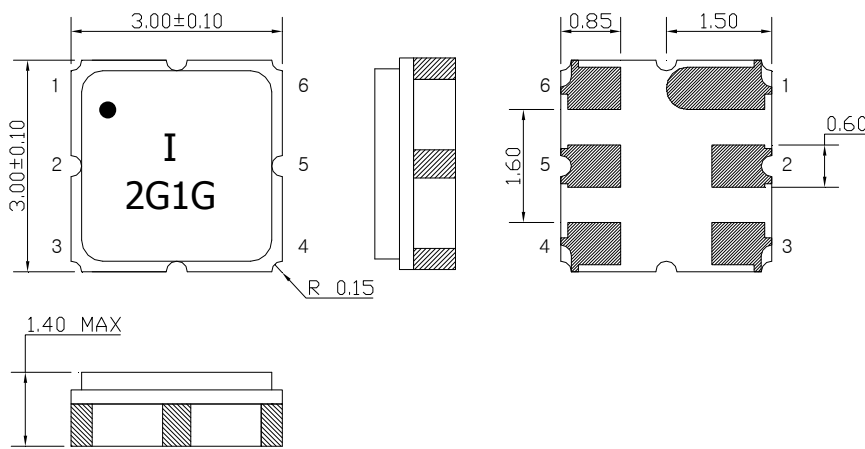

Dimensions shown are nominal in millimeters

Body : Al₂O₃ Ceramic

Lid : Kovar, Ni Plated

Terminations : Au plating 0.3 ~ 1.0 um, Over a 1.27 ~ 8.89 um
Ni Plating

Pin Configurations

2	Input
5	Output
1, 3, 4, 6	Case ground

Maximum Ratings

Parameter	Unit	Minimum	Typical	Maximum
Operating Temperature Range	℃	-20	25	70
Storage Temperature Range	℃	-40	25	85
Power Handling Capability	dBm	-	-	10

Electrostatics Sensitive Device (ESD)

	ITF Co., Ltd. 102-901, Bucheon Technopark 364, Samjeong-Dong, Ojeong-Gu, Bucheon-City, Gyeonggi-Do, Korea 421-809	Part No.	F2G1G	
		Rev. Date	2017-7-10	
		Rev.	AS 01	1/7

SAW Bandpass Filter F2G1G



Specifications

Fc = 2155 MHz

	Minimum	Typical	Maximum	Unit
Center Frequency (Fc)	-	2155	-	MHz
Insertion Loss (2110 ~ 2200 MHz)	-	2.7	5.0	dB
Amplitude Ripple (2110 ~ 2200 MHz)	-	1.8	3.0	dB p-p
VSWR (2110 ~ 2200 MHz)	-	1.8	2.5	
Attenuation				
10 ~ 2060 MHz	25	26	-	dB
2250 ~ 3200 MHz	25	33	-	
Input/Output Impedance		50		Ohms

Notes :

- 1) All specifications are based on the matching schematic shown below, measured by Agilent Network analyzer and full 2 port calibration.
- 2) Electrical margin has been built into the design to account for the variations due to temperature drift and manufacturing tolerances

 Integrated Technology Future	ITF Co., Ltd. 102-901, Bucheon Technopark 364, Samjeong-Dong, Ojeong-Gu, Bucheon-City, Gyeonggi-Do, Korea 421-809	Part No.	F2G1G	
		Rev. Date	2017-7-10	
		Rev.	AS 01	2/7

SAW Bandpass Filter F2G1G



Matching Schematic

(Actual matching values may vary due to PCB layout and parasitics)



Marking Configuration

- ¹⁾
I²⁾
2G1G³⁾

- 1) Pad Number 1 Index
- 2) Manufacturer name
- 3) Marking Number

* Ink or Laser Marking available

 Integrated Technology Future	ITF Co., Ltd. 102-901, Bucheon Technopark 364, Samjeong-Dong, Ojeong-Gu, Bucheon-City, Gyeonggi-Do, Korea 421-809	Part No.	F2G1G	
		Rev. Date	2017-7-10	
		Rev.	AS 01	3/7

SAW Bandpass Filter F2G1G



Typical Performance (at 25°C)

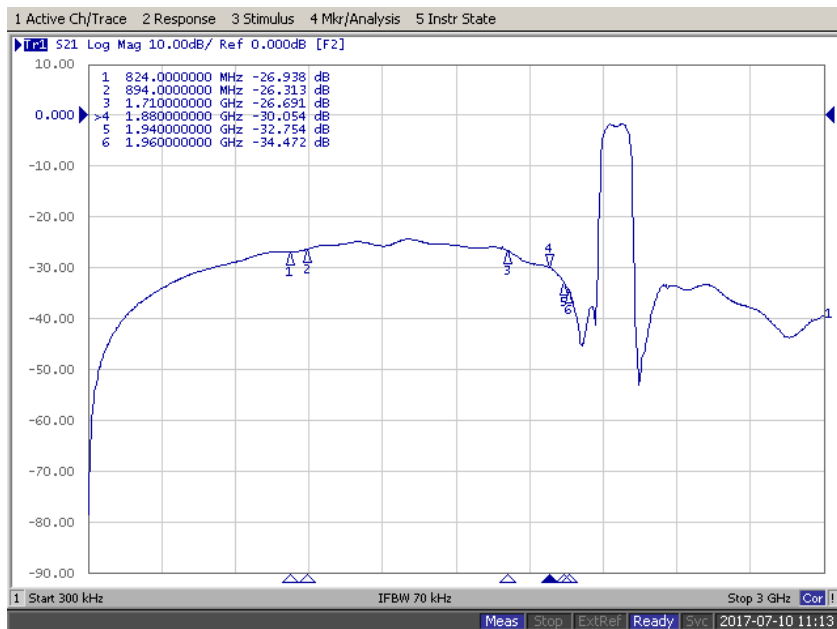
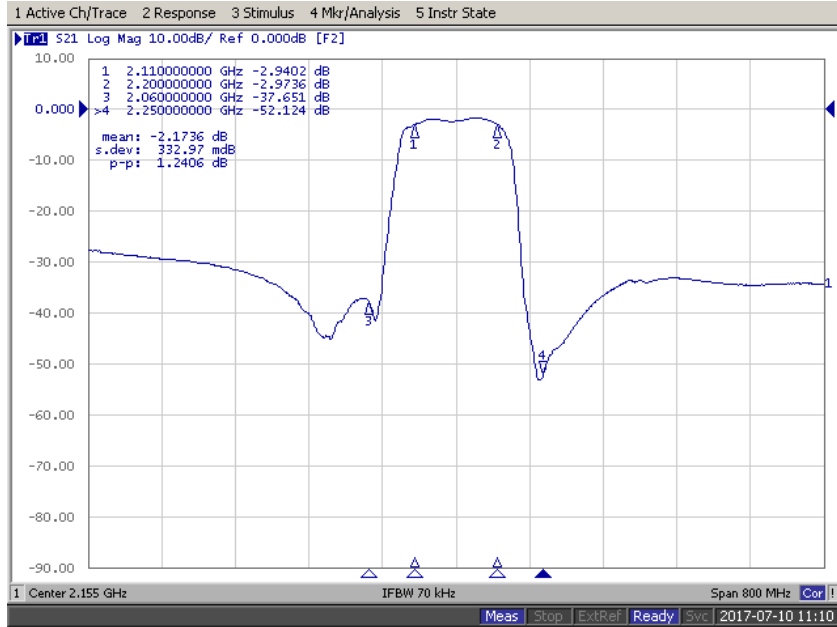

ITF Co., Ltd.
 102-901, Bucheon Technopark 364,
 Samjeong-Dong, Ojeong-Gu, Bucheon-City,
 Gyeonggi-Do, Korea 421-809

Part No.	F2G1G	
Rev. Date	2017-7-10	
Rev.	AS 01	4/7

SAW Bandpass Filter F2G1G



Input / Output VSWR

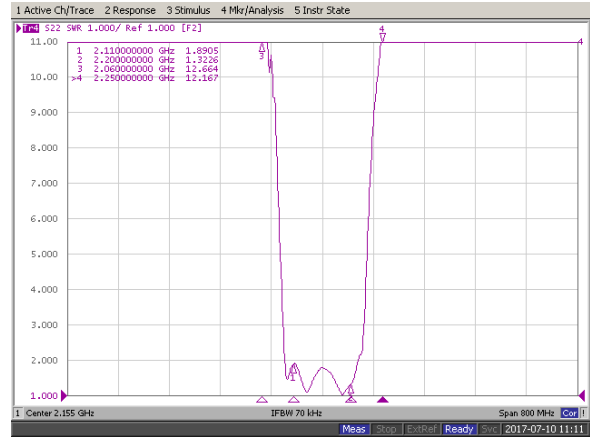
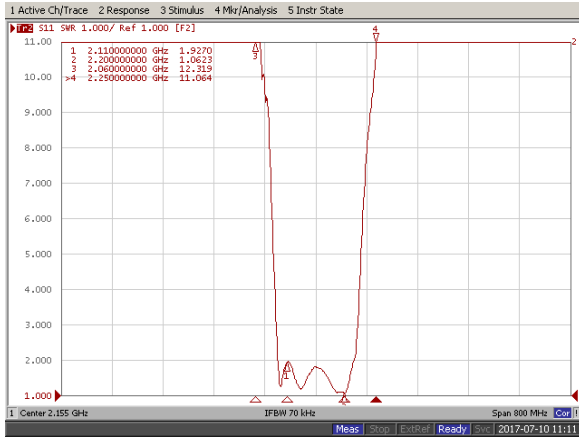

Input / Output Smith Charts

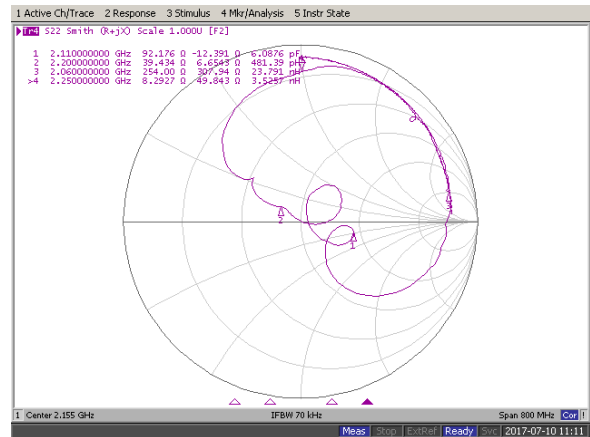
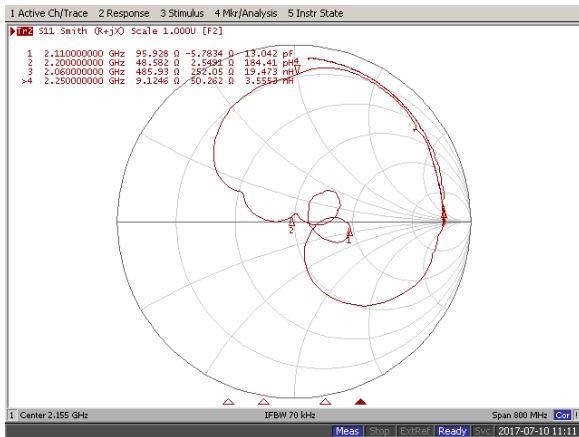

ITF Co., Ltd.
 102-901, Bucheon Technopark 364,
 Samjeong-Dong, Ojeong-Gu, Bucheon-City,
 Gyeonggi-Do, Korea 421-809

Part No.	F2G1G	
Rev. Date	2017-7-10	
Rev.	AS 01	5/7

SAW Bandpass Filter F2G1G



Packing Specifications

1. Reeling Quantity : 3000 pcs / 13" reel (or 1000 pcs / 7" reel)
2. Taping Structure : The tape shall be wound around the reel in the direction shown below.

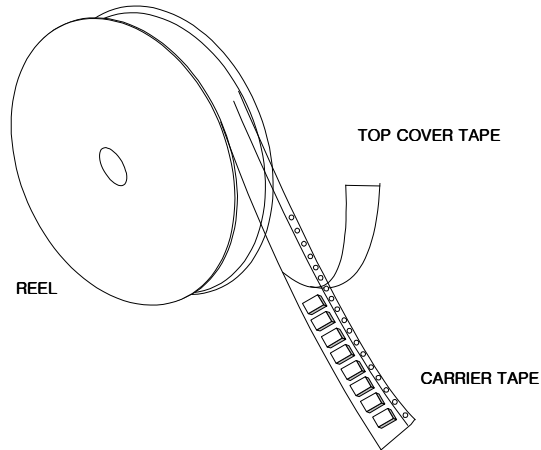

Tape Specification

1. Leader part and vacant position specification

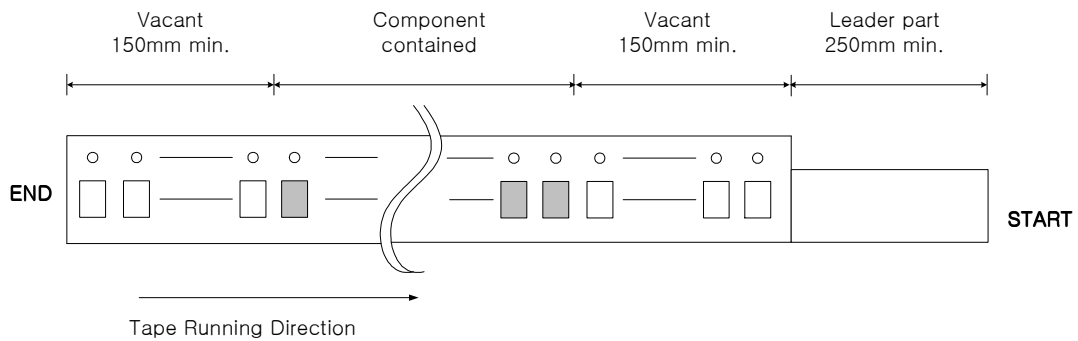

2. Tensile strength of carrier tape

4.4N/mm width

3. Top cover tape adhesion

- 1) pull off angle : 0~15°
- 2) speed : 300mm/min
- 3) force : 20~70g

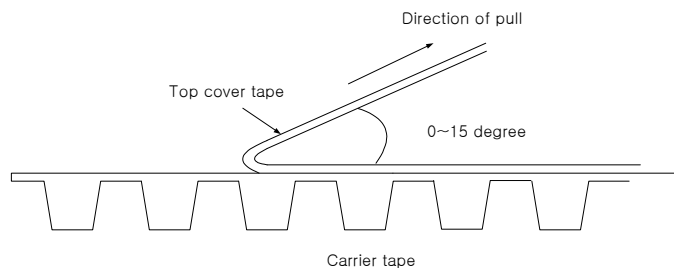

	ITF Co., Ltd. 102-901, Bucheon Technopark 364, Samjeong-Dong, Ojeong-Gu, Bucheon-City, Gyeonggi-Do, Korea 421-809	Part No.	F2G1G	
		Rev. Date	2017-7-10	
		Rev.	AS 01	6/7

SAW Bandpass Filter F2G1G



Carrier Tape Dimensions [unit : mm]

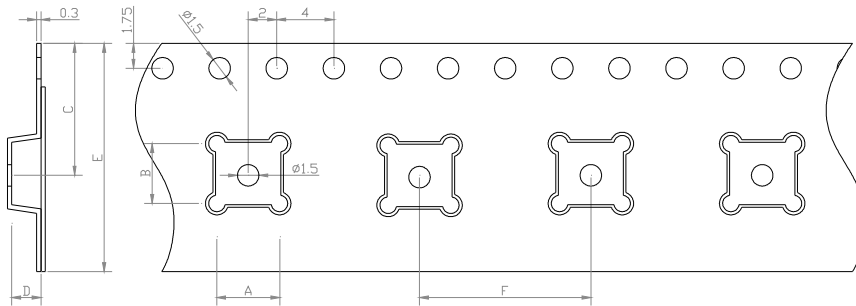

A	3.40 ± 0.1
B	3.40 ± 0.1
C	7.25 ± 0.1
D	1.70 ± 0.1
E	12.00 ± 0.1
F	8.00 ± 0.1

Part Direction

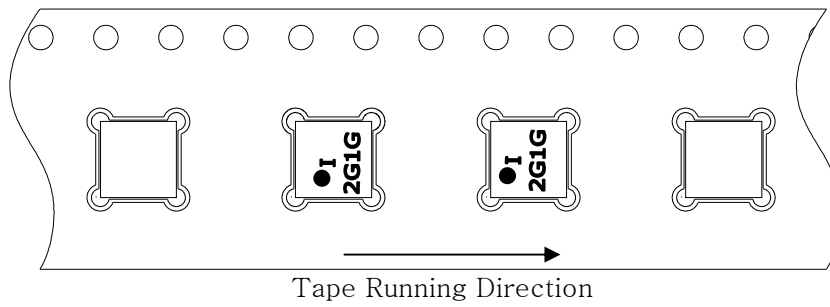

Reel Dimensions [unit : mm]

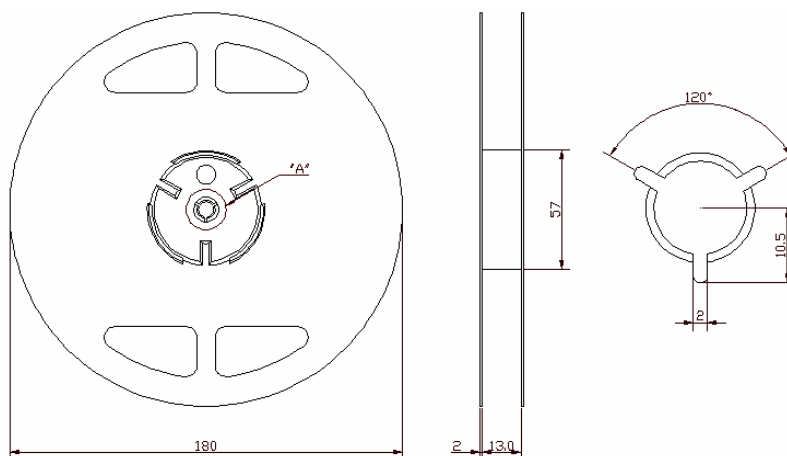

	ITF Co., Ltd. 102-901, Bucheon Technopark 364, Samjeong-Dong, Ojeong-Gu, Bucheon-City, Gyeonggi-Do, Korea 421-809	Part No.	F2G1G	
		Rev. Date	2017-7-10	
		Rev.	AS 01	7/7