

SAW Bandpass Filter F1G61



Features

- RF bandpass filter
- High attenuation
- No matching 50Ω single-ended operation
- Ceramic Surface Mounted Device (SMD) Package (3.0 mm * 3.0 mm)
- RoHS Compliant

Package Dimensions

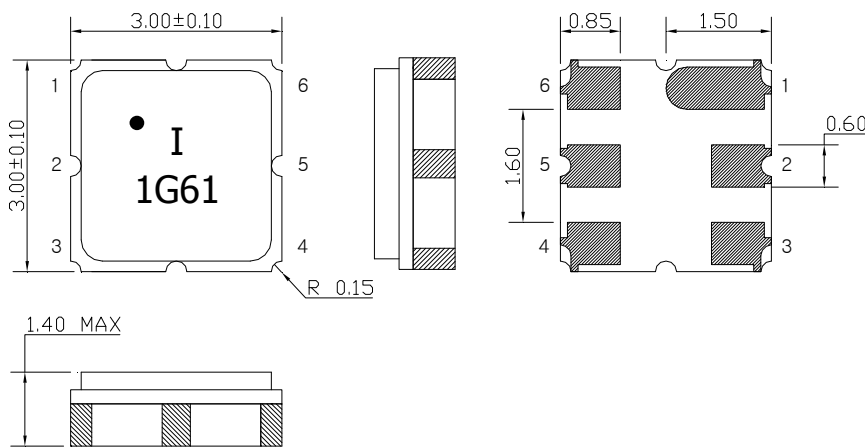

Dimensions shown are nominal in millimeters

Body : Al₂O₃ Ceramic

Lid : Kovar, Ni Plated

Terminations : Au plating 0.3 ~ 1.0 um, Over a 1.27 ~ 8.89 um
Ni Plating

Pin Configuration

2	Input
5	Output
1, 3, 4, 6	Case ground

Maximum Ratings

Parameter	Unit	Minimum	Typical	Maximum
Operating Temperature Range	℃	-25	25	70
Storage Temperature Range	℃	-30	25	85
Power Handling Capability	dBm	-	10	-

Electrostatics Sensitive Device (ESD)

	ITF Co., Ltd. 102-901, Bucheon Technopark 364, Samjeong-Dong, Ojeong-Gu, Bucheon-City, Gyeonggi-Do, Korea 421-809	Part No.	NCNA03-F1G61	
		Rev. Date	2012-3-27	
		Rev.	AS 01	1/7

SAW Bandpass Filter F1G61



Specifications

$F_c = 1649.5 \text{ MHz}$

Terminating source impedance : 50Ω

Terminating load impedance : 50Ω

	Minimum	Typical	Maximum	Unit
Center Frequency (F_c)	-	1649.5	-	MHz
Insertion Loss (In $F_c \pm 21 \text{ MHz}$)	-	4.0	5.0	dB
Amplitude Ripple (In $F_c \pm 21 \text{ MHz}$)	-	1.2	2.0	dBp-p
VSWR (In $F_c \pm 21 \text{ MHz}$)	-	1.7	2.5	
Relative Attenuation				
DC ~ 1576.5 MHz	40	49	-	dB
At 1593 MHz	35	54	-	
1593 ~ 1605 MHz	19	41	-	
At 1751 MHz	25	44	-	
2400 ~ 2500 MHz	40	44.5	-	
Input/Output Impedance		50		Ohms

Notes :

- 1) All specifications are based on the matching schematic shown below, measured by Agilent Network analyzer and full 2 port calibration.
- 2) Electrical margin has been built into the design to account for the variations due to temperature drift and manufacturing tolerances

 Integrated Technology Future	ITF Co., Ltd. 102-901, Bucheon Technopark 364, Samjeong-Dong, Ojeong-Gu, Bucheon-City, Gyeonggi-Do, Korea 421-809	Part No.	NCNA03-F1G61	
		Rev. Date	2012-3-27	
		Rev.	AS 01	2/7

SAW Bandpass Filter F1G61



Matching Schematic

(Actual matching values may vary due to PCB layout and parasitics)



Marking Configuration

- ¹⁾
I²⁾
1G61³⁾

- 1) Pad Number 1 Index
- 2) Manufacturer name
- 3) Marking Number

* Ink or Laser Marking available

	ITF Co., Ltd. 102-901, Bucheon Technopark 364, Samjeong-Dong, Ojeong-Gu, Bucheon-City, Gyeonggi-Do, Korea 421-809	Part No.	NCNA03-F1G61	
		Rev. Date	2012-3-27	
		Rev.	AS 01	3/7

SAW Bandpass Filter F1G61



Typical Performance (at 25°C)

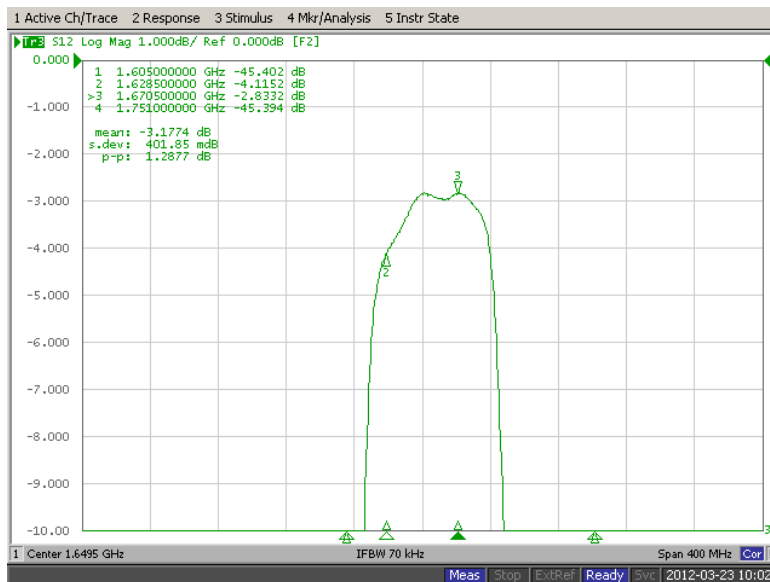
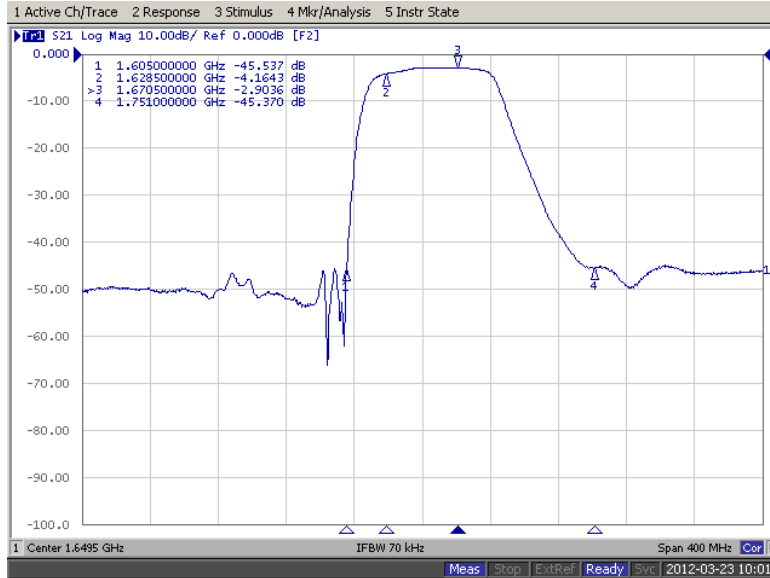

 <p>ITF Co., Ltd. 102-901, Bucheon Technopark 364, Samjeong-Dong, Ojeong-Gu, Bucheon-City, Gyeonggi-Do, Korea 421-809</p>	Part No.	NCNA03-F1G61	
	Rev. Date	2012-3-27	
	Rev.	AS 01	4/7

SAW Bandpass Filter F1G61



Input / Output VSWR Charts

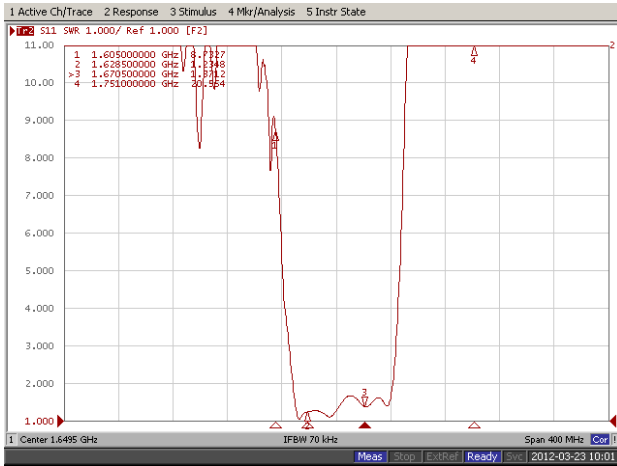

Input / Output Smith Charts

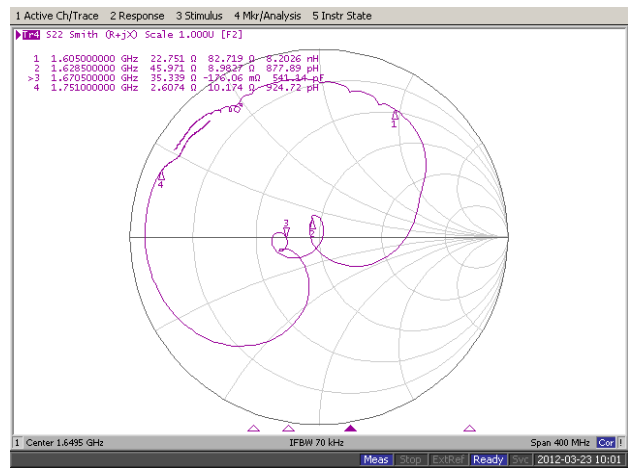
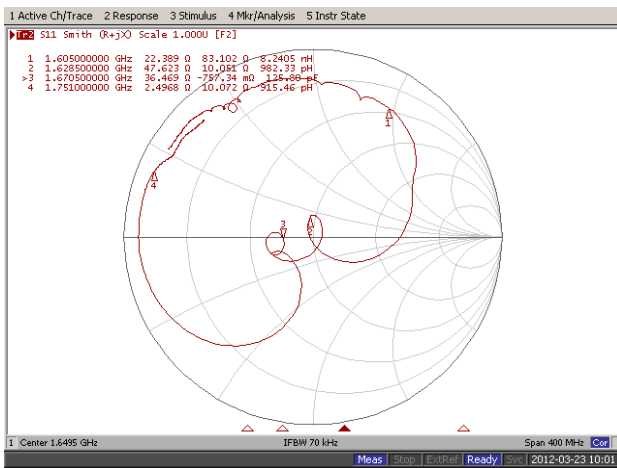

ITF Co., Ltd.
 102-901, Bucheon Technopark 364,
 Samjeong-Dong, Ojeong-Gu, Bucheon-City,
 Gyeonggi-Do, Korea 421-809

Part No.	NCNA03-F1G61	
Rev. Date	2012-3-27	
Rev.	AS 01	5/7

SAW Bandpass Filter F1G61



Packing Specification

1. Reeling Quantity : 3000 pcs / 13" reel (or 1000 pcs / 7" reel)
2. Taping Structure : The tape shall be wound around the reel in the direction shown below.

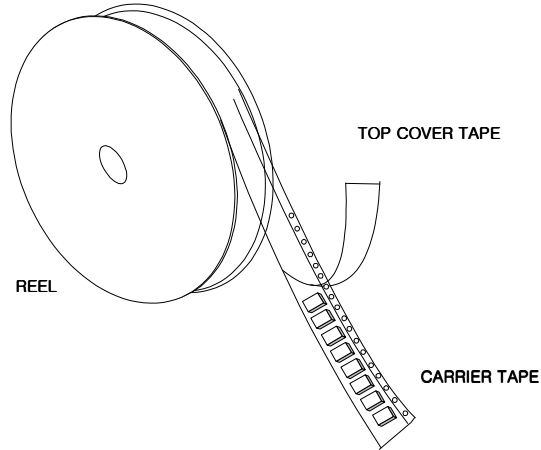

Tape Specification

1. Leader part and vacant position specification

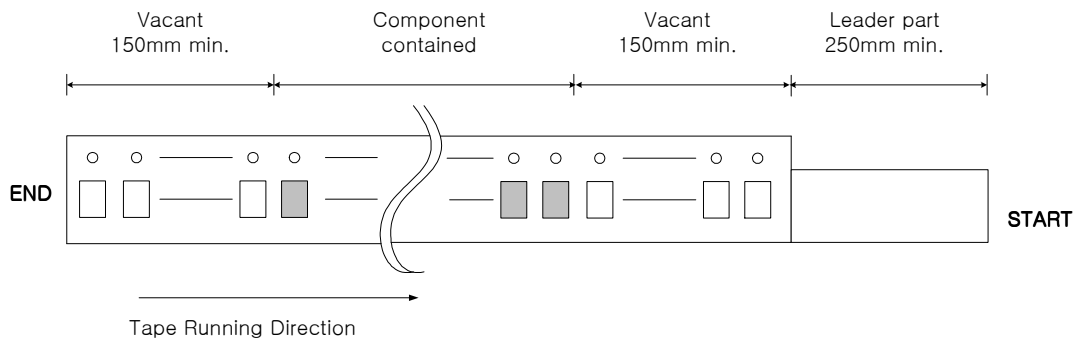

2. Tensile strength of carrier tape

4.4N/mm width

3. Top cover tape adhesion

- 1) pull off angle : 0~15°
- 2) speed : 300mm/min
- 3) force : 20~70g

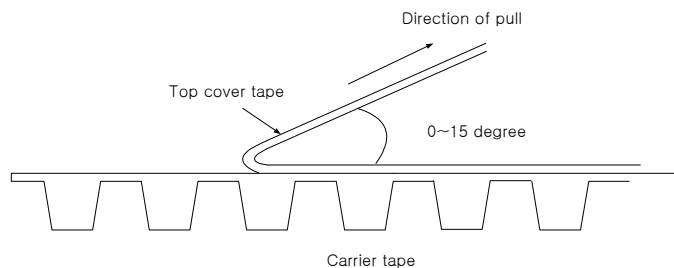

	ITF Co., Ltd. 102-901, Bucheon Technopark 364, Samjeong-Dong, Ojeong-Gu, Bucheon-City, Gyeonggi-Do, Korea 421-809	Part No.	NCNA03-F1G61	
		Rev. Date	2012-3-27	
		Rev.	AS 01	6/7

SAW Bandpass Filter F1G61



Carrier Tape Dimensions [unit : mm]

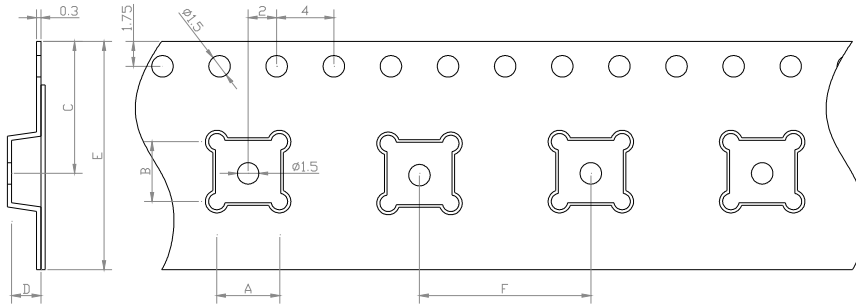

A	3.40 ± 0.1
B	3.40 ± 0.1
C	7.25 ± 0.1
D	1.70 ± 0.1
E	12.00 ± 0.1
F	8.00 ± 0.1

Part Direction

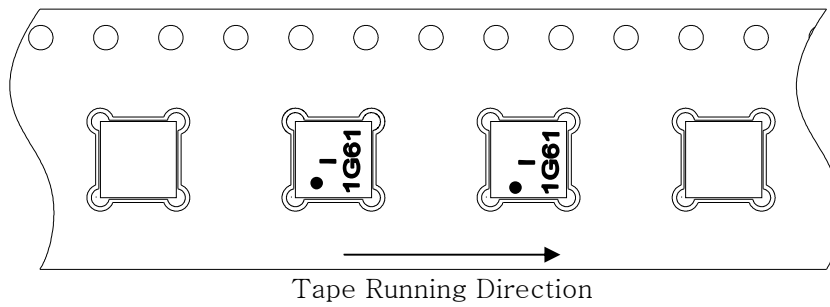

Reel Dimensions [unit : mm]

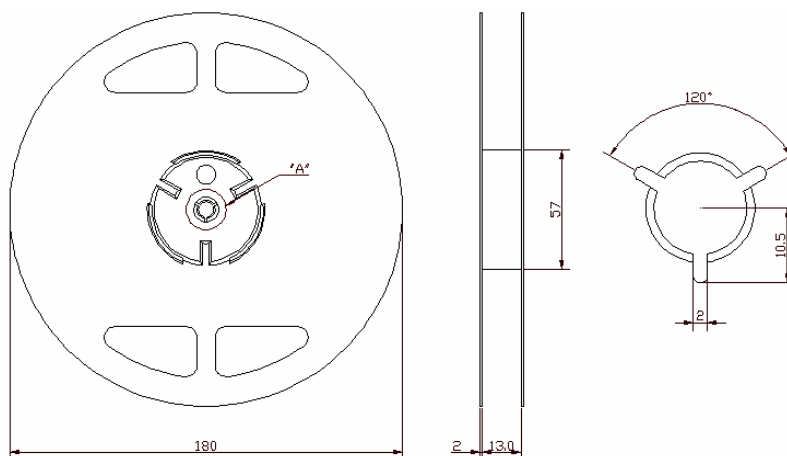

	ITF Co., Ltd. 102-901, Bucheon Technopark 364, Samjeong-Dong, Ojeong-Gu, Bucheon-City, Gyeonggi-Do, Korea 421-809	Part No.	NCNA03-F1G61	
		Rev. Date	2012-3-27	
		Rev.	AS 01	7/7