

SAW Bandpass Filter F4546



Features

- RF SAW Bandpass Filter
- Passband 1.0MHz
- Ceramic Surface Mounted Device (SMD) Package
- RoHS/RoHS2 Compliant

Package Dimensions

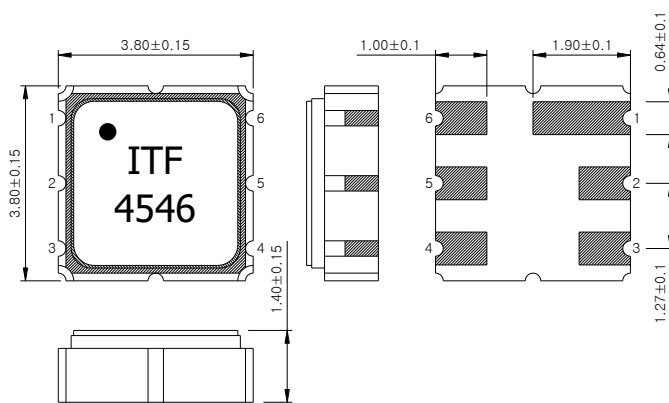

Dimensions shown are nominal in millimeters

Body : Al₂O₃ Ceramic

Lid : Kovar, Ni Plated

Terminations : Au plating 0.3 ~ 1.0 um, Over a 1.27 ~ 8.89 um
Ni Plating

Pin Configuration	
2	Input
5	Output
1, 3, 4, 6	Ground

Maximum Ratings

Parameter	Unit	Minimum	Typical	Maximum
Operating Temperature Range	°C	-20		60
Storage Temperature Range	°C	-20	-	70
DC Voltage	V	-	-	7.5
Power Handling Capability	dBm	-	-	20

Electrostatics Sensitive Device (ESD)

	ITF Co., Ltd. 102-701, 22, Samjak-ro, Ojeong-gu, Bucheon-si, Gyeonggi-do, Korea, 14501	Part No.	F4546	
		Rev. Date	2020-07-08	
		Rev.	NRVG02-AS01	1/8

SAW Bandpass Filter F4546



Specifications

Fc = 454.1 MHz

		Minimum	Typical	Maximum
Center Frequency (Fc)	MHz	-	454.1	-
Insertion Loss (Fc ± 0.5MHz)	dB	-	1.8	3.0
Amplitude Ripple (Fc ± 0.5MHz)	dB	-	0.2	1.5
Absolute Attenuation				
432.7 MHz	dB	50	60	-
475.5 MHz		50	60	-
Input/Output impedance	Ohm	-	50	-

Notes :

- 1) All specifications are based on the matching schematic shown below, measured by Agilent Network analyzer and full 2 port calibration.
- 2) Electrical margin has been built into the design to account for the variations due to temperature drift and manufacturing tolerances

 Integrated Technology Future	ITF Co., Ltd. 102-701, 22, Samjak-ro, Ojeong-gu, Bucheon-si, Gyeonggi-do, Korea, 14501	Part No.	F4546	
		Rev. Date	2020-07-08	
		Rev.	NRVG02-AS01	2/8

SAW Bandpass Filter F4546



Matching Schematic

(Actual matching values may vary due to PCB layout and parasitics)

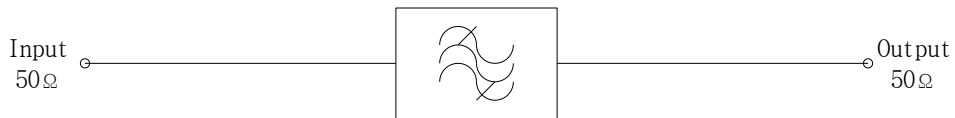

Marking Configuration

●¹⁾
ITF²⁾
4546³⁾

1) Pad Number 1 Index

2) Manufacturer name

3) Marking Number

* Ink or Laser Marking available

	ITF Co., Ltd. 102-701, 22, Samjak-ro, Ojeong-gu, Bucheon-si, Gyeonggi-do, Korea, 14501	Part No.	F4546	
		Rev. Date	2020-07-08	
		Rev.	NRVG02-AS01	3/8

SAW Bandpass Filter F4546



Typical Performance (at 25°C)

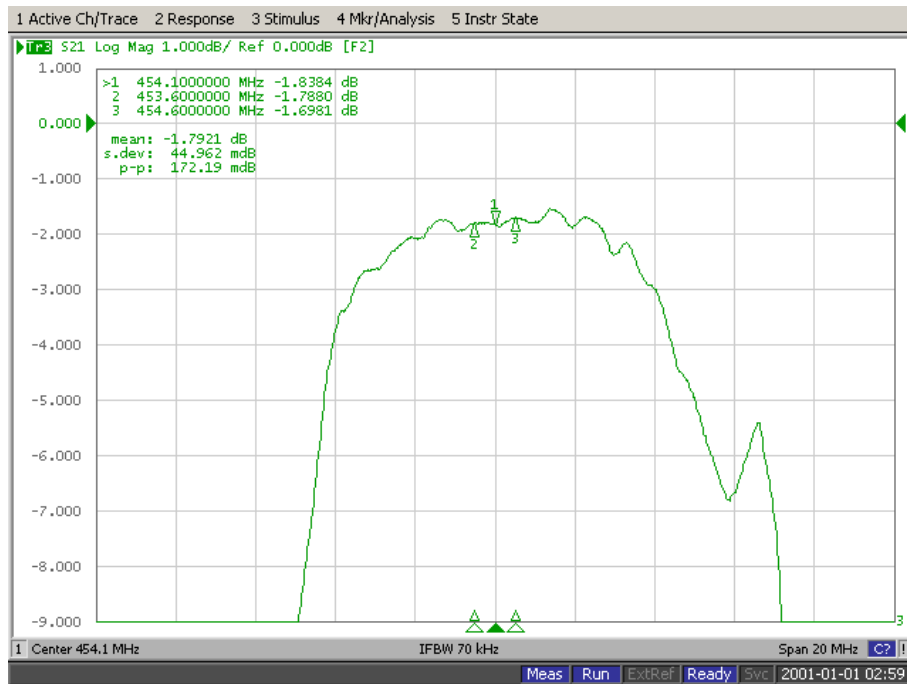
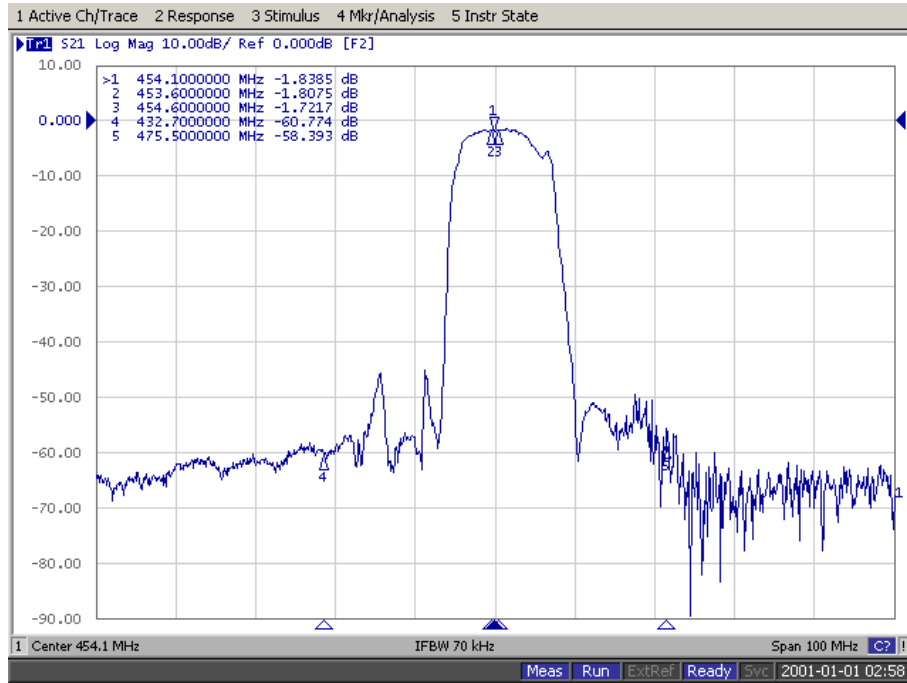

	ITF Co., Ltd. 102-701, 22, Samjak-ro, Ojeong-gu, Bucheon-si, Gyeonggi-do, Korea, 14501	Part No.	F4546	
		Rev. Date	2020-07-08	
		Rev.	NRVG02-AS01	4/8

SAW Bandpass Filter F4546



Input / Output VSWR Charts

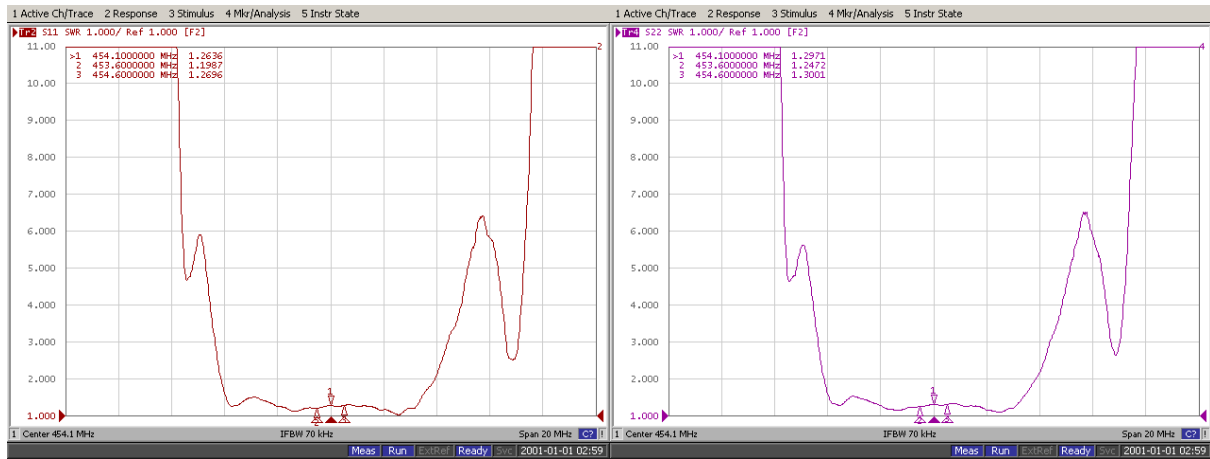

Input / Output Smith Charts

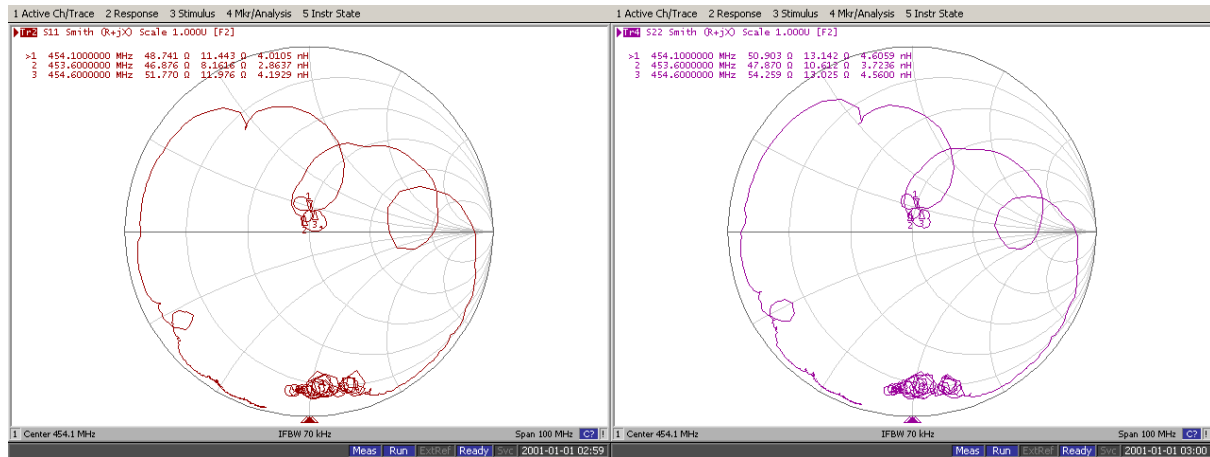

ITF Co., Ltd.
102-701, 22, Samjak-ro, Ojeong-gu,
Bucheon-si, Gyeonggi-do, Korea, 14501

Part No.	F4546	
Rev. Date	2020-07-08	
Rev.	NRVG02-AS01	5/8

SAW Bandpass Filter F4546



Packing Specification

1. Reeling Quantity : 1000 pcs / reel or 3000 pcs / reel
2. Taping Structure : The tape shall be wound around the reel in the direction shown below.

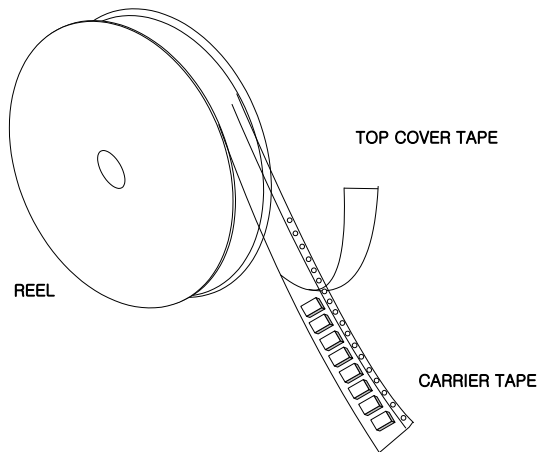

Tape Specification

1. Leader part and vacant position specification

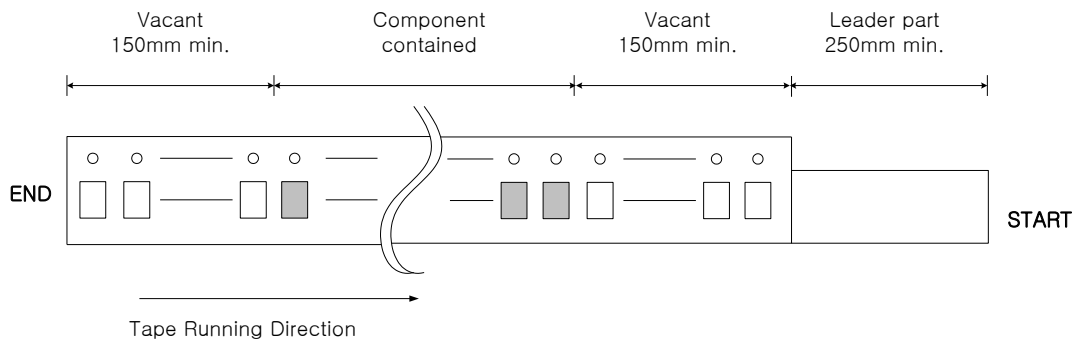

2. Tensile strength of carrier tape

4.4N/mm width

3. Top cover tape adhesion

- 1) pull off angle : 0~15°
- 2) speed : 300mm/min
- 3) force : 20~70g

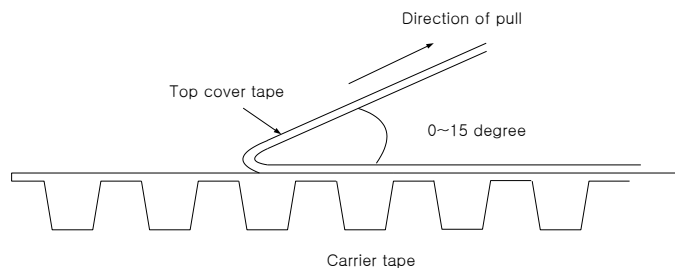

	ITF Co., Ltd. 102-701, 22, Samjak-ro, Ojeong-gu, Bucheon-si, Gyeonggi-do, Korea, 14501	Part No.	F4546	
		Rev. Date	2020-07-08	
		Rev.	NRVG02-AS01	6/8

SAW Bandpass Filter F4546



Carrier Tape Dimensions [unit : mm]

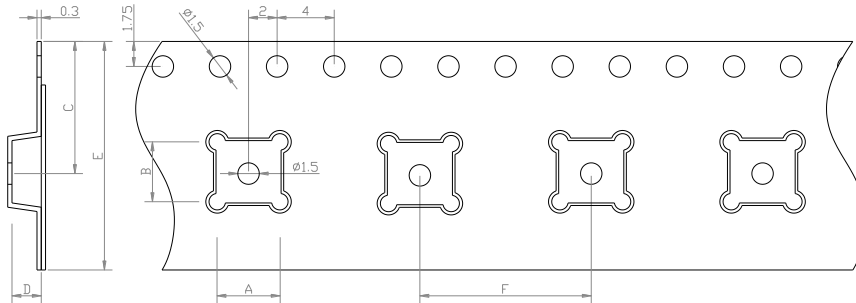

A	4.30 ± 0.1
B	4.30 ± 0.1
C	7.25 ± 0.1
D	1.70 ± 0.1
E	12.00 ± 0.1
F	8.00 ± 0.1

Part Direction

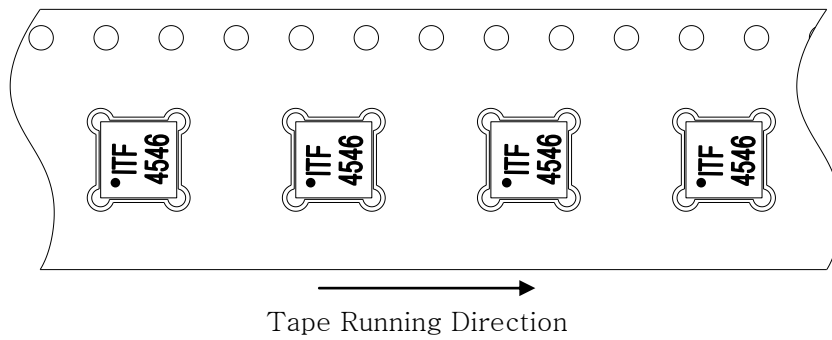

Reel Dimensions [unit : mm]

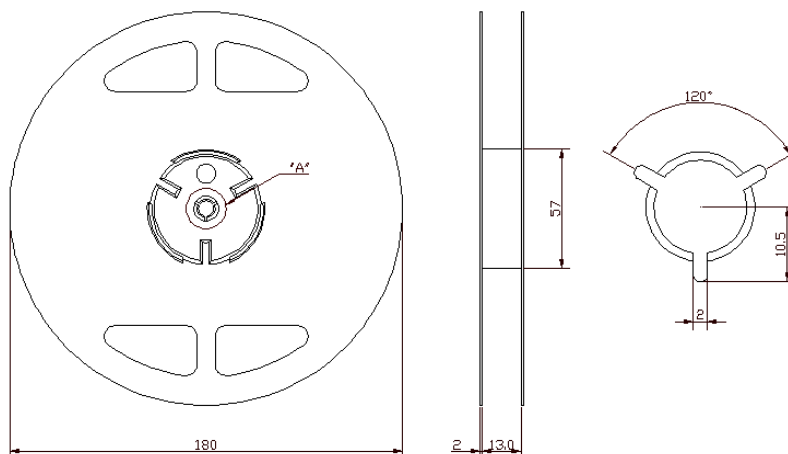

	ITF Co., Ltd. 102-701, 22, Samjak-ro, Ojeong-gu, Bucheon-si, Gyeonggi-do, Korea, 14501	Part No.	F4546	
		Rev. Date	2020-07-08	
		Rev.	NRVG02-AS01	7/8

SAW Bandpass Filter F4546



Reflow Condition

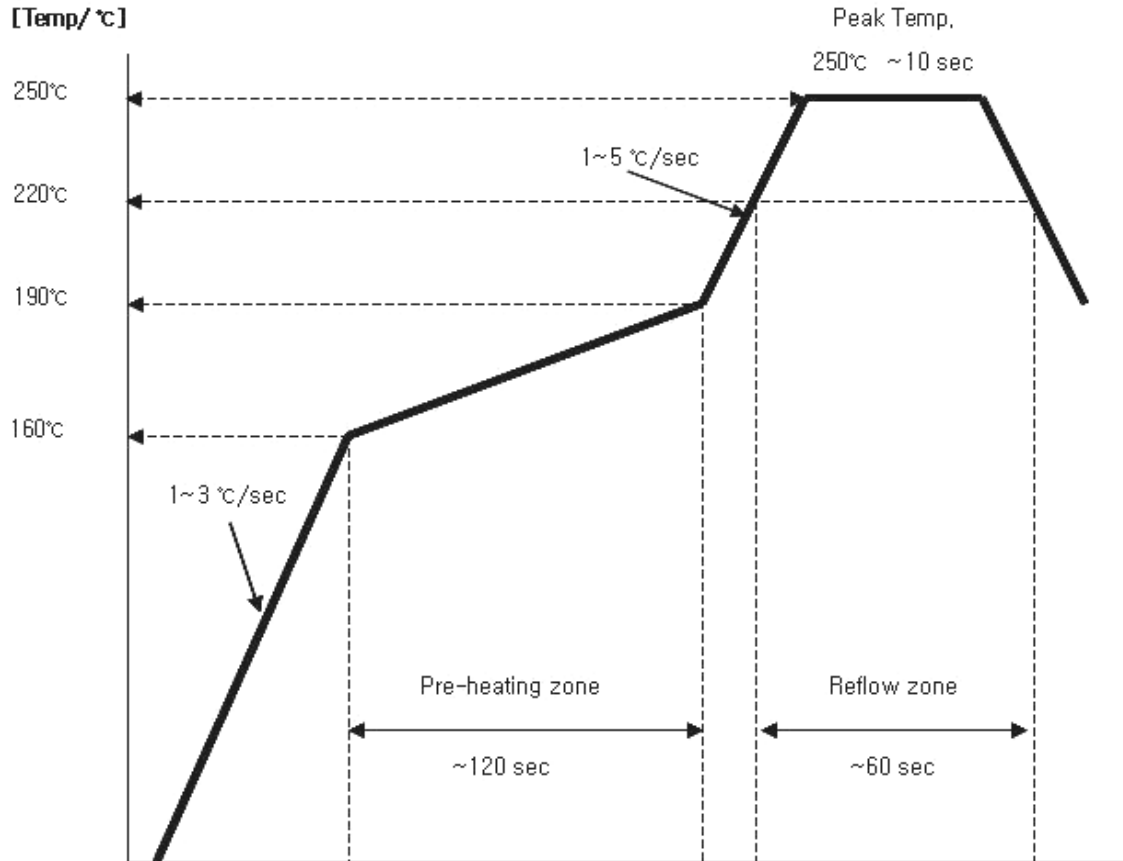

Comment) The quality is guaranteed under this temperature conditions on 2 times solder reflows

Cautions

1. This is a hermetic device.

MSL (Moisture Sensitive Level) is the 1st level

2. This is an electrostatic sensitive device. Please avoid static voltage during operation and storage.

ESD (Electrostatic Discharge) Rating is class 0. (Test : HBM-Human Body Model)

3. Ultrasonic cleaning shall be avoided.

4. This device should not be used in any type of fluid such as water, oil , organic solvent ,etc.

	ITF Co., Ltd. 102-701, 22, Samjak-ro, Ojeong-gu, Bucheon-si, Gyeonggi-do, Korea, 14501	Part No.	F4546	
		Rev. Date	2020-07-08	
		Rev.	NRVG02-AS01	8/8