

SAW Bandpass Filter F4295



Features

- RF bandpass filter
- Usable bandwidth 1.0 MHz
- Ceramic Surface Mounted Device (SMD) Package (3.8mm × 3.8mm)
- RoHS/RoHS2(2015/863/EU) Compliant

Package Dimensions

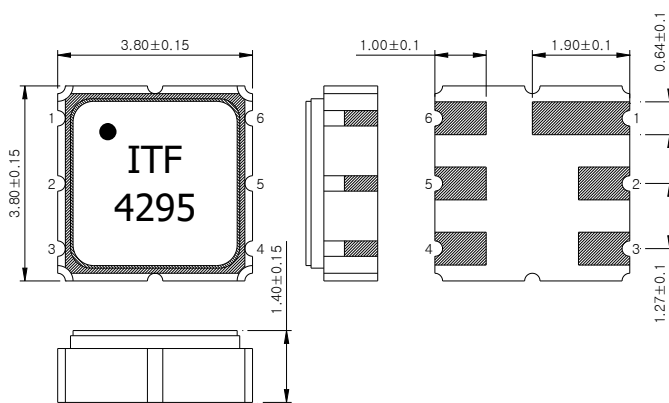

Recommended Footprint

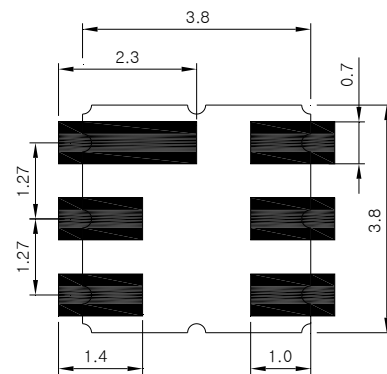

Dimensions shown are nominal in millimeters

Body : Al₂O₃ Ceramic

Lid : Kovar, Ni Plated

Terminations : Au plating 0.3 ~ 1.0 um, Over a 1.27 ~ 8.89 um Ni Plating

| Pin Configuration | |
|-------------------|--------|
| 2 | Input |
| 5 | Output |
| 1, 3, 4, 6 | Ground |

Maximum Ratings

| Parameter | Unit | Minimum | Typical | Maximum |
|-----------------------------|------|---------|---------|---------|
| Operating Temperature Range | °C | -20 | 25 | 65 |
| Storage Temperature Range | °C | -20 | - | 70 |
| Maximum Input Power | dBm | - | - | 20 |
| Maximum DC Voltage | V | - | - | 7.5 |

Electrostatics Sensitive Device (ESD)

| | | | | |
|---|---|-----------|-------------|-----|
|  | ITF Co., Ltd. 102-901, Bucheon Technopark 364, Samjeong-Dong, Ojeong-Gu, Bucheon-City, Gyeonggi-Do, Korea 421-809 | Part No. | F4295 | |
| | | Rev. Date | 2020-06-01 | |
| | | Rev. | NRUi02-AS01 | 1/9 |

SAW Bandpass Filter F4295



Specifications

Fc = 429.42.0 MHz

| | | Minimum | Typical | Maximum |
|--|-----|---------|---------|---------|
| Center Frequency (Fc) | MHz | - | 429.42 | - |
| Insertion Loss (428.92 ~ 429.92 MHz) | dB | - | 2.0 | 2.5 |
| Amplitude Ripple (428.92 ~ 429.92 MHz) | dB | - | 0.4 | 1.0 |
| VSWR (428.92 ~ 429.92 MHz) | | - | 1.3 | 2.5 |
| Absolute Attenuation | | | | |
| 386.62 MHz | dB | 50 | 69 | - |
| 408.02 MHz | | 50 | 63 | - |
| Input/Output impedance | Ohm | - | 50 | - |

Notes :

- 1) All specifications are based on the matching schematic shown below, measured by Agilent Network analyzer and full 2 port calibration.
- 2) Electrical margin has been built into the design to account for the variations due to temperature drift and manufacturing tolerances

| | | | | |
|---|---|-----------|-------------|-----|
|  Integrated Technology Future | ITF Co., Ltd. 102-901, Bucheon Technopark 364, Samjeong-Dong, Ojeong-Gu, Bucheon-City, Gyeonggi-Do, Korea 421-809 | Part No. | F4295 | |
| | | Rev. Date | 2020-06-01 | |
| | | Rev. | NRUi02-AS01 | 2/9 |

SAW Bandpass Filter F4295



Matching Schematic

(Actual matching values may vary due to PCB layout and parasitics)

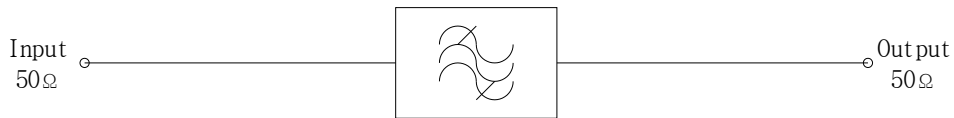

Marking Configuration

- ¹⁾
ITF ²⁾
4295 ³⁾

1) Pad Number 1 Index

2) Manufacturer name

3) Marking Number

* Ink or Laser Marking available

| | | | | |
|---|---|-----------|-------------|-----|
|  Integrated Technology Future | ITF Co., Ltd. 102-901, Bucheon Technopark 364, Samjeong-Dong, Ojeong-Gu, Bucheon-City, Gyeonggi-Do, Korea 421-809 | Part No. | F4295 | |
| | | Rev. Date | 2020-06-01 | |
| | | Rev. | NRUi02-AS01 | 3/9 |

SAW Bandpass Filter F4295



Typical Performance (at 25°C)

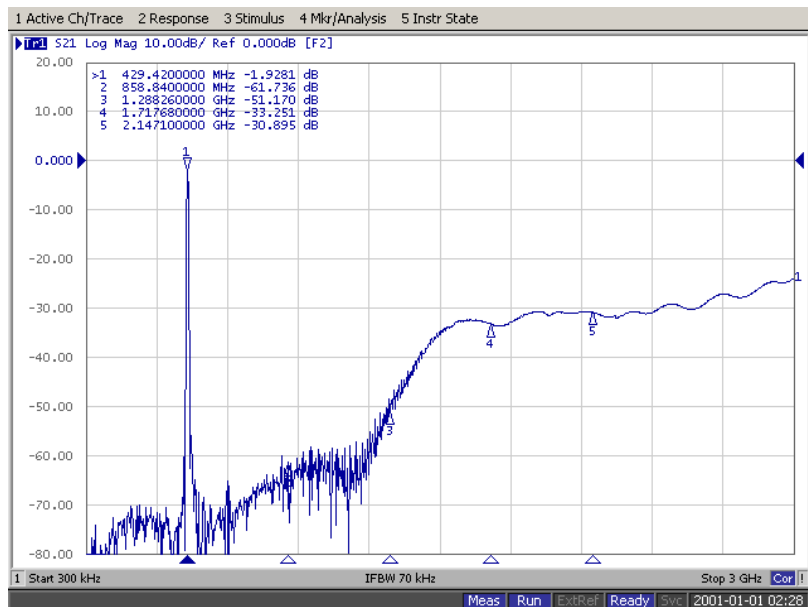
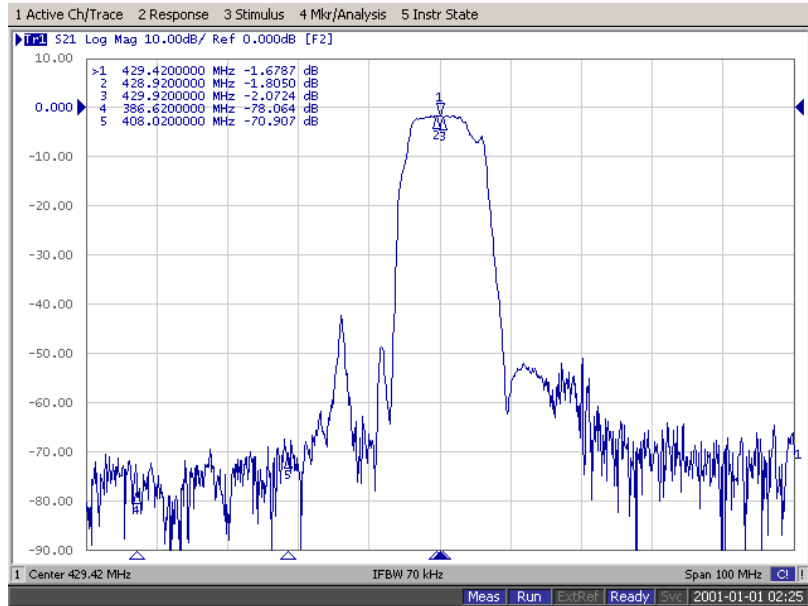

| | | | | |
|--|---|-----------|-------------|-----|
| | ITF Co., Ltd. 102-901, Bucheon Technopark 364, Samjeong-Dong, Ojeong-Gu, Bucheon-City, Gyeonggi-Do, Korea 421-809 | Part No. | F4295 | |
| | | Rev. Date | 2020-06-01 | |
| | | Rev. | NRUi02-AS01 | 4/9 |
| | | | | |

SAW Bandpass Filter F4295



Input / Output VSWR Charts

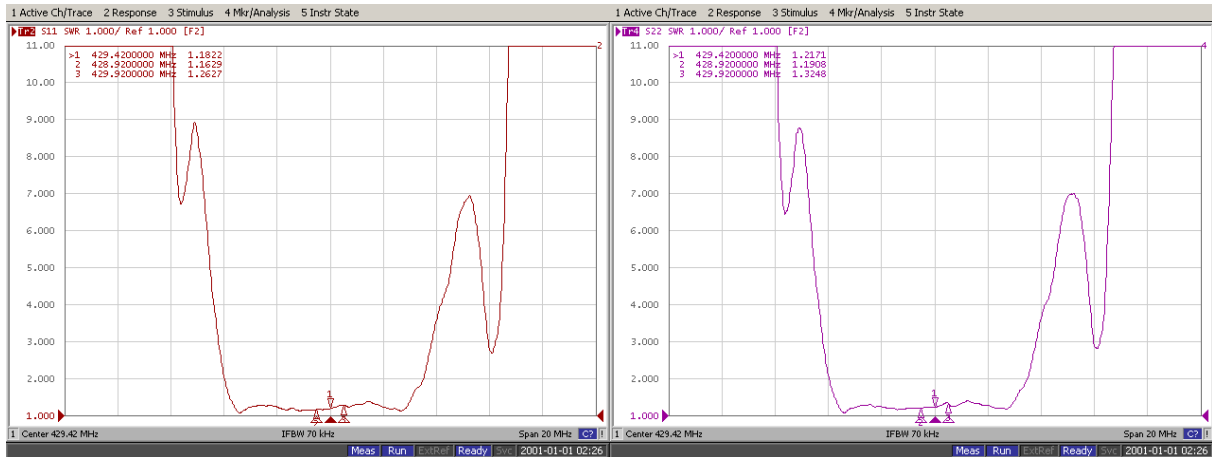

Input / Output Smith Charts

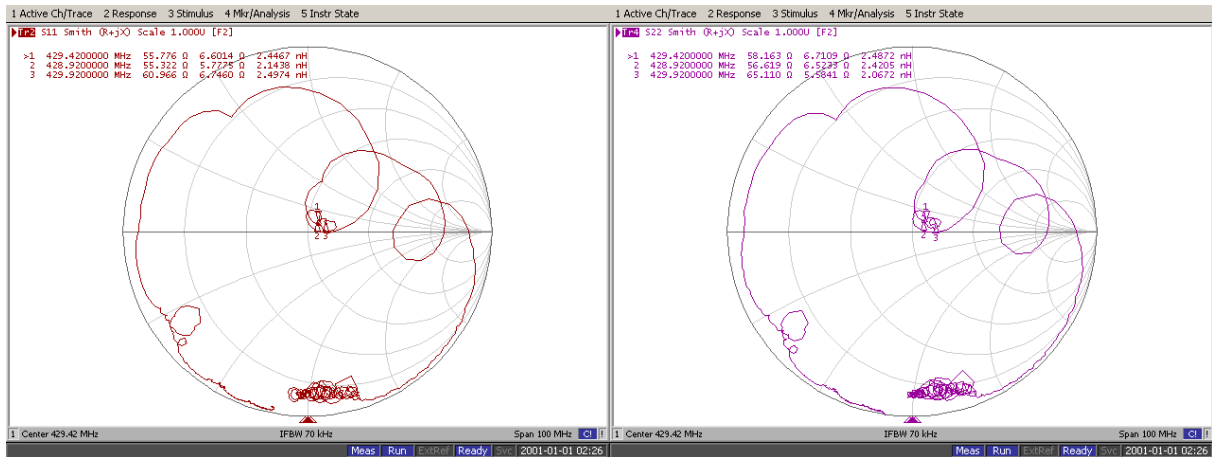

| | | | | |
|--|---|-----------|-------------|-----|
| | ITF Co., Ltd. 102-901, Bucheon Technopark 364, Samjeong-Dong, Ojeong-Gu, Bucheon-City, Gyeonggi-Do, Korea 421-809 | Part No. | F4295 | |
| | | Rev. Date | 2020-06-01 | |
| | | Rev. | NRUi02-AS01 | 5/9 |

SAW Bandpass Filter F4295



Packing Specification

1. Reeling Quantity : 1000 pcs / reel or 3000 pcs / reel
2. Taping Structure : The tape shall be wound around the reel in the direction shown below.

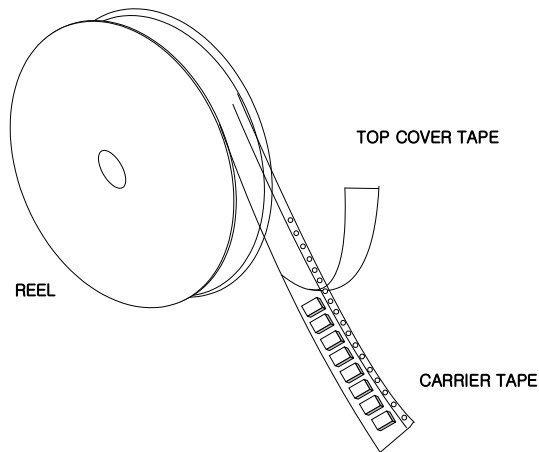

Tape Specification

1. Leader part and vacant position specification

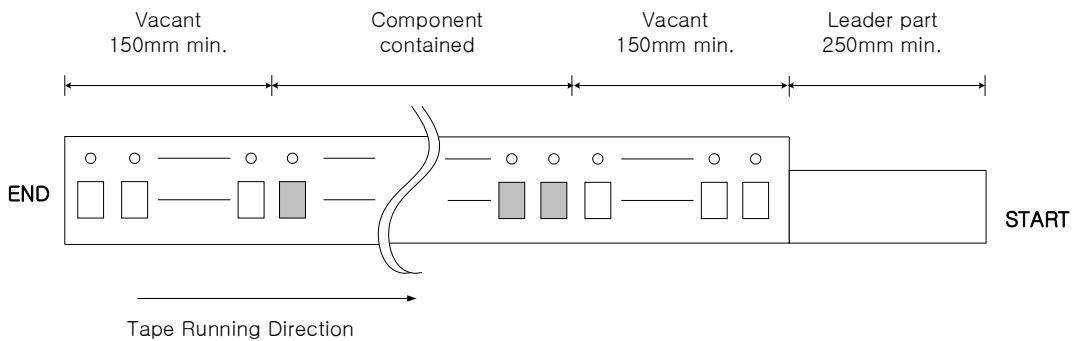



2. Tensile strength of carrier tape

4.4N/mm width

3. Top cover tape adhesion

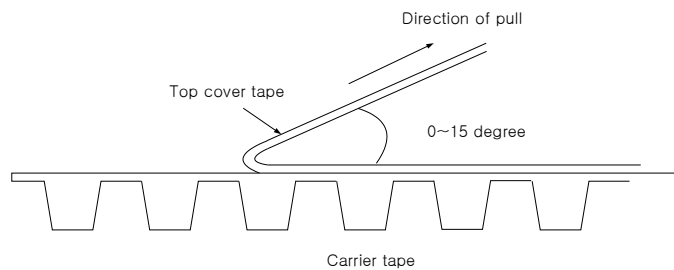
- 1) pull off angle : 0~15°
- 2) speed : 300mm/min
- 3) force : 20~70g



| | | | | |
|---|---|-----------|-------------|-----|
|  Integrated Technology Future | ITF Co., Ltd. 102-901, Bucheon Technopark 364, Samjeong-Dong, Ojeong-Gu, Bucheon-City, Gyeonggi-Do, Korea 421-809 | Part No. | F4295 | |
| | | Rev. Date | 2020-06-01 | |
| | | Rev. | NRUi02-AS01 | 6/9 |

SAW Bandpass Filter F4295



Carrier Tape Dimensions [unit : mm]

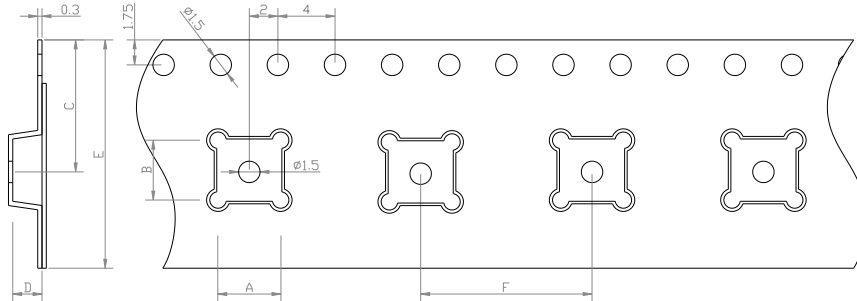

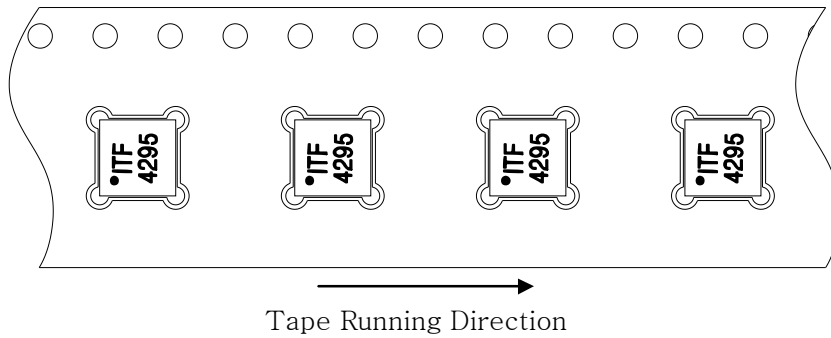

| | |
|---|-------------|
| A | 4.30 ± 0.1 |
| B | 4.30 ± 0.1 |
| C | 7.25 ± 0.1 |
| D | 1.70 ± 0.1 |
| E | 12.00 ± 0.1 |
| F | 8.00 ± 0.1 |

Part Direction

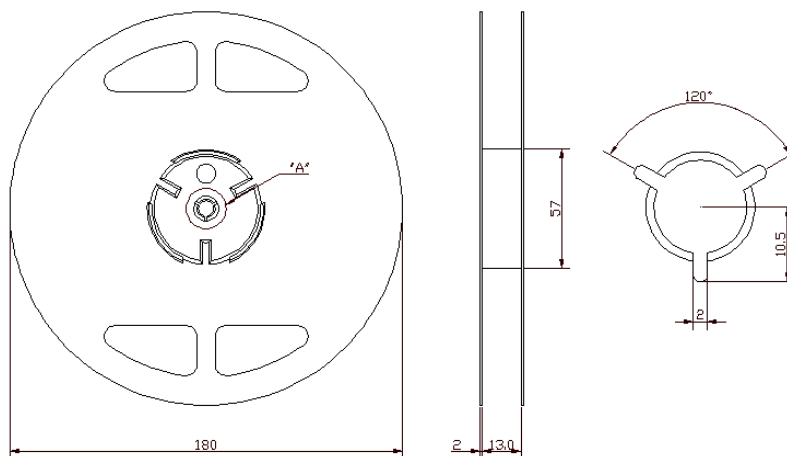

Reel Dimensions [unit : mm]



| | | | | |
|---|---|-----------|-------------|-----|
|  | ITF Co., Ltd. 102-901, Bucheon Technopark 364, Samjeong-Dong, Ojeong-Gu, Bucheon-City, Gyeonggi-Do, Korea 421-809 | Part No. | F4295 | |
| | | Rev. Date | 2020-06-01 | |
| | | Rev. | NRUi02-AS01 | 7/9 |

SAW Bandpass Filter F4295



Label Form



Packaging Box [unit : cm]

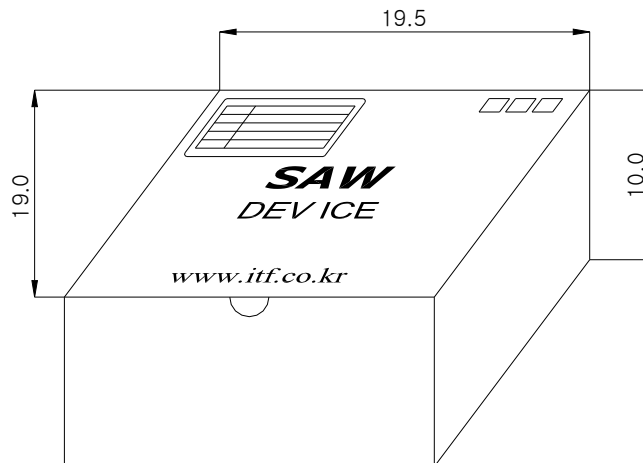
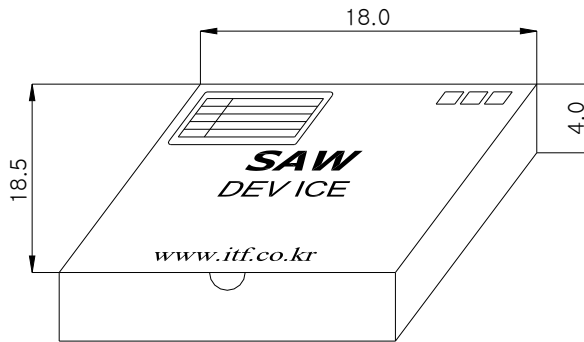

| | | | | |
|---|---|-----------|-------------|-----|
|  Integrated Technology Future | ITF Co., Ltd. 102-901, Bucheon Technopark 364, Samjeong-Dong, Ojeong-Gu, Bucheon-City, Gyeonggi-Do, Korea 421-809 | Part No. | F4295 | |
| | | Rev. Date | 2020-06-01 | |
| | | Rev. | NRUi02-AS01 | 8/9 |

Reflow Condition

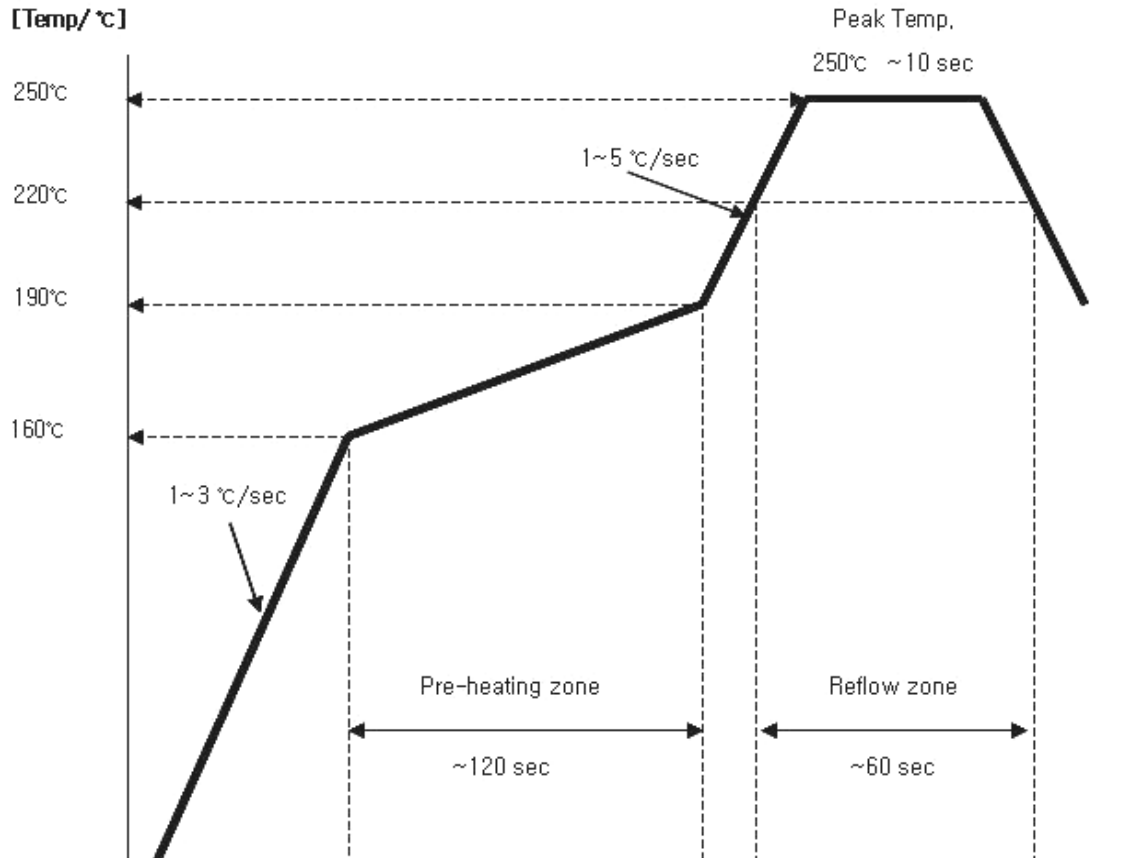

Comment) The quality is guaranteed under this temperature conditions on 2 times solder reflows

Cautions

1. This is a hermetic device.

MSL (Moisture Sensitive Level) is the 1st level

2. This is an electrostatic sensitive device. Please avoid static voltage during operation and storage.

ESD (Electrostatic Discharge) Rating is class 0. (Test : HBM-Human Body Model)

3. Ultrasonic cleaning shall be avoided.

4. This device should not be used in any type of fluid such as water, oil , organic solvent ,etc.

| | | | | |
|---|---|-----------|-------------|-----|
|  Integrated Technology Future | ITF Co., Ltd. 102-901, Bucheon Technopark 364, Samjeong-Dong, Ojeong-Gu, Bucheon-City, Gyeonggi-Do, Korea 421-809 | Part No. | F4295 | |
| | | Rev. Date | 2020-06-01 | |
| | | Rev. | NRUi02-AS01 | 9/9 |