

SAW Bandpass Filter 920 MHz



Features

- RF bandpass filter for RF-ID System
- Usable bandwidth 2 MHz (919 ~ 921 MHz)
- Single-ended operation
- Ceramic Surface Mounted Device Package (3.8 mm × 3.8 mm)
- RoHS Compliant

Package Dimensions

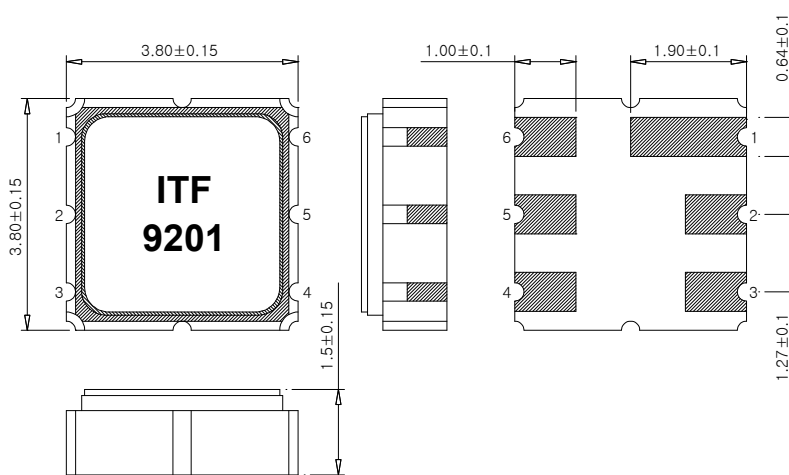

Dimensions shown are nominal in millimeters

Body : Al₂O₃ Ceramic

Lid : Kovar, Ni Plated

Terminations : Au plating 0.3 ~ 1.0 um, Over a 1.27 ~ 8.89 um Ni Plating

Pin Configurations	
2	Input
5	Output
1, 3, 4, 6	Case ground

Maximum Ratings

Parameters	Unit	Minimum	Typical	Maximum
Operating Temperature Range	°C	-30	25	75
Storage Temperature Range	°C	-40	25	85
Power Handling Capability	dBm	-	-	10

Electrostatics Sensitive Device (ESD)

	ITF Co., Ltd. 102-901, Bucheon Technopark 364, Samjeong-Dong, Ojeong-Gu, Bucheon-City, Gyeonggi-Do, Korea 421-809	Part No.	F9201	
		Rev. Date	2012-12-14	
		Rev.	NRNL02-AS01	1/7

SAW Bandpass Filter 920 MHz



Specifications

Fc = 920 MHz

	Minimum	Typical	Maximum	Unit
Center Frequency (Fc)	-	920.0	-	MHz
Insertion Loss (919 ~ 921 MHz)	-	6.0	7.0	dB
Amplitude Ripple (919 ~ 921 MHz)	-	1.0	2.0	dB
Relative Attenuation				
At 914.5 MHz	25	30	-	dB
At 917.5 MHz	20	28	-	
Input/Output Impedance		50		Ohm

Notes :

- 1) All specifications are based on the matching schematic shown below, measured by Agilent Network analyzer and full 2 port calibration.
- 2) Electrical margin has been built into the design to account for the variations due to temperature drift and manufacturing tolerances

 Integrated Technology Future	ITF Co., Ltd. 102-901, Bucheon Technopark 364, Samjeong-Dong, Ojeong-Gu, Bucheon-City, Gyeonggi-Do, Korea 421-809	Part No.	F9201	
		Rev. Date	2012-12-14	
		Rev.	NRNL02-AS01	2/7

SAW Bandpass Filter 920 MHz



Matching Schematic

(Actual matching values may vary due to PCB layout and parasitics)

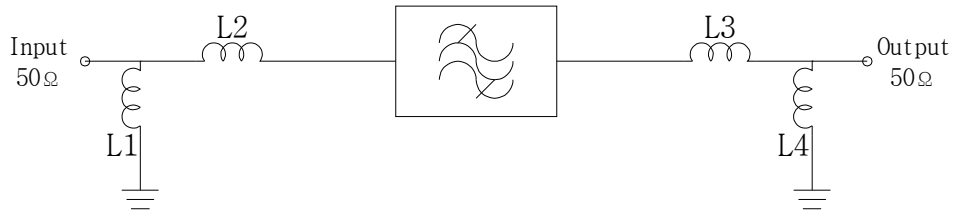

L1 , L4= 3.9 nH , L2 , L3 = 4.3 nH

Marking Configuration

ITF ¹⁾

9201 ²⁾

1) Manufacturer name

2) Marking Number

* Ink or Laser Marking available

 Integrated Technology Future	ITF Co., Ltd. 102-901, Bucheon Technopark 364, Samjeong-Dong, Ojeong-Gu, Bucheon-City, Gyeonggi-Do, Korea 421-809	Part No.	F9201	
		Rev. Date	2012-12-14	
		Rev.	NRNL02-AS01	3/7

SAW Bandpass Filter 920 MHz



Typical Performance

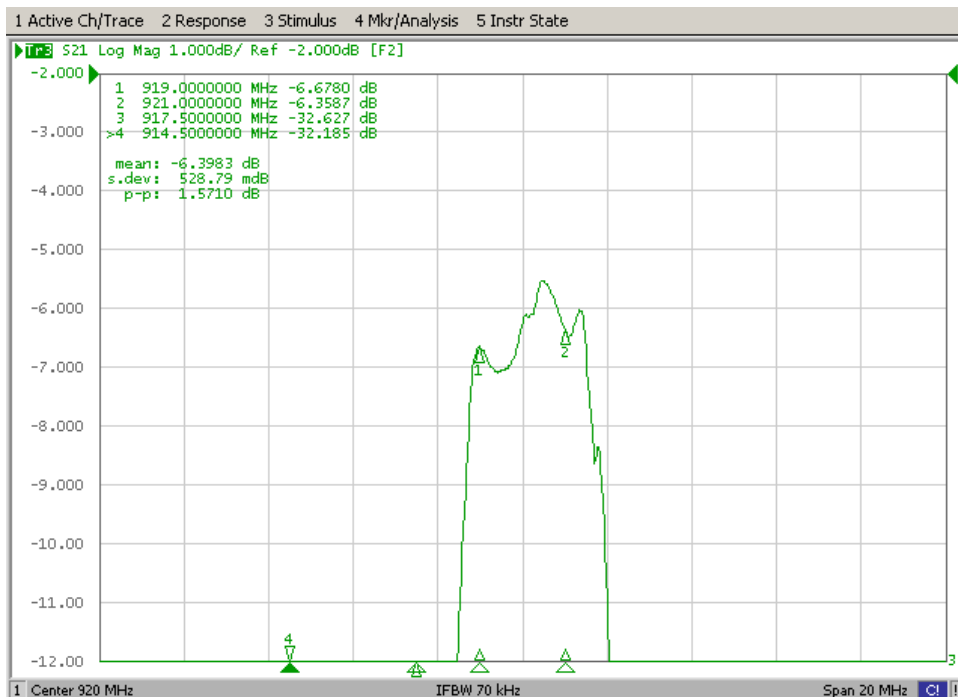
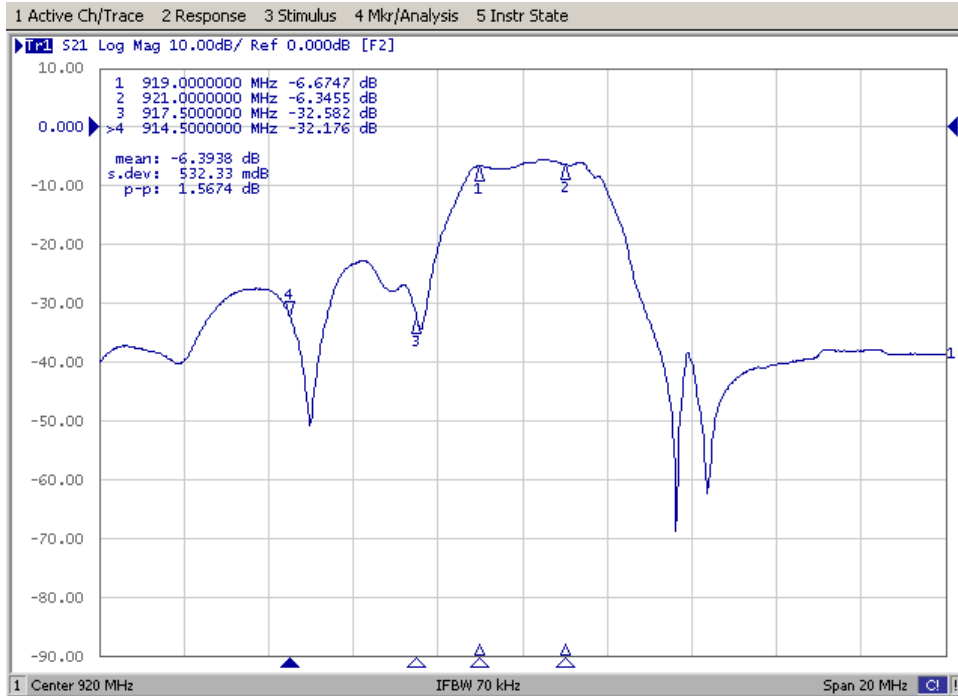

	ITF Co., Ltd. 102-901, Bucheon Technopark 364, Samjeong-Dong, Ojeong-Gu, Bucheon-City, Gyeonggi-Do, Korea 421-809	Part No.	F9201	
		Rev. Date	2012-12-14	
		Rev.	NRNL02-AS01	4/7

SAW Bandpass Filter 920 MHz



Input / Output Smith chart

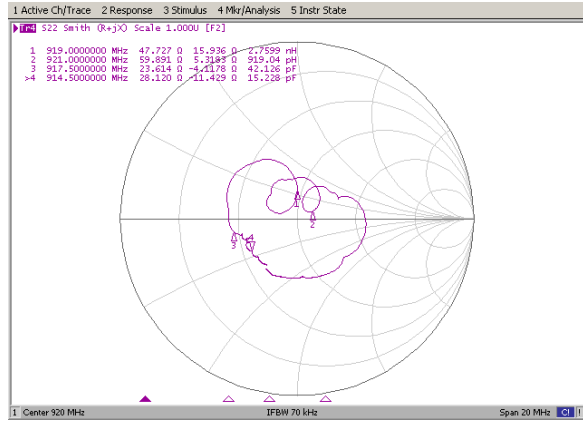
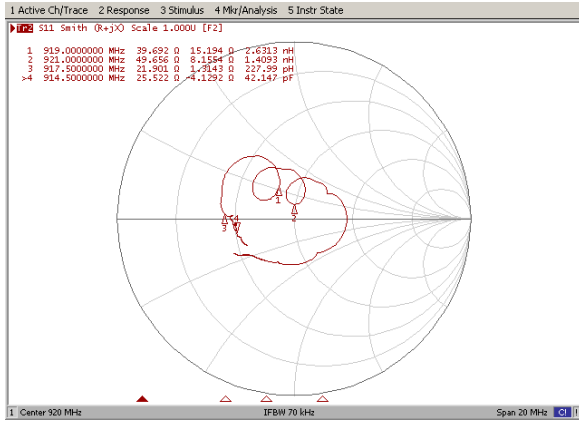

Input / Output VSWR

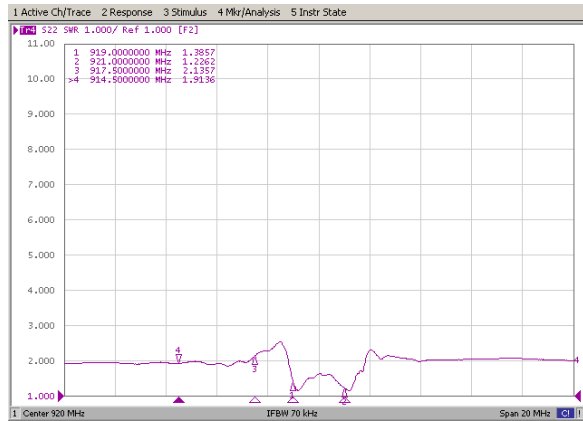
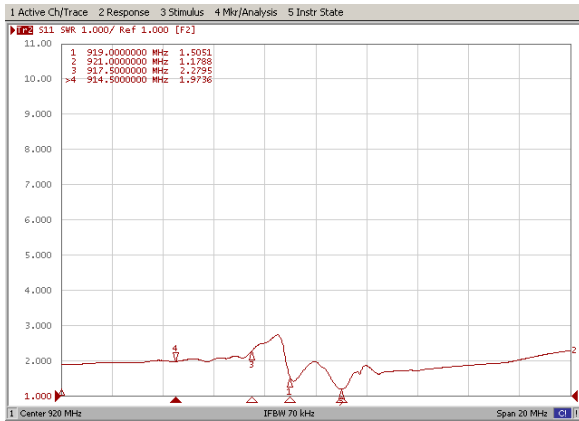

	ITF Co., Ltd. 102-901, Bucheon Technopark 364, Samjeong-Dong, Ojeong-Gu, Bucheon-City, Gyeonggi-Do, Korea 421-809	Part No.	F9201	
		Rev. Date	2012-12-14	
		Rev.	NRNL02-AS01	5/7

SAW Bandpass Filter 920 MHz



Packing Specification

1. Reeling Quantity : 3000 pcs / 13" reel (or 1000 pcs / 7" reel)
2. Taping Structure : The tape shall be wound around the reel in the direction shown below.

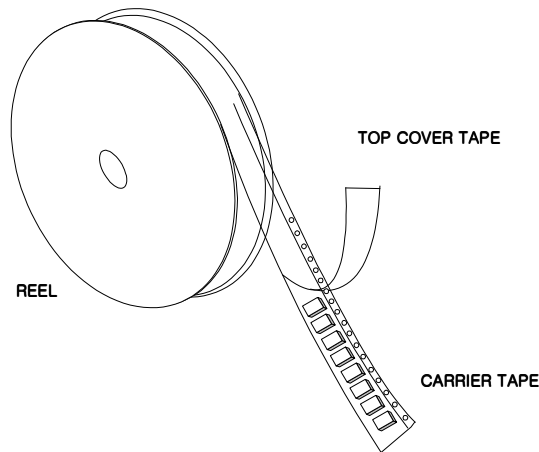

Tape Specification

1. Leader part and vacant position specification

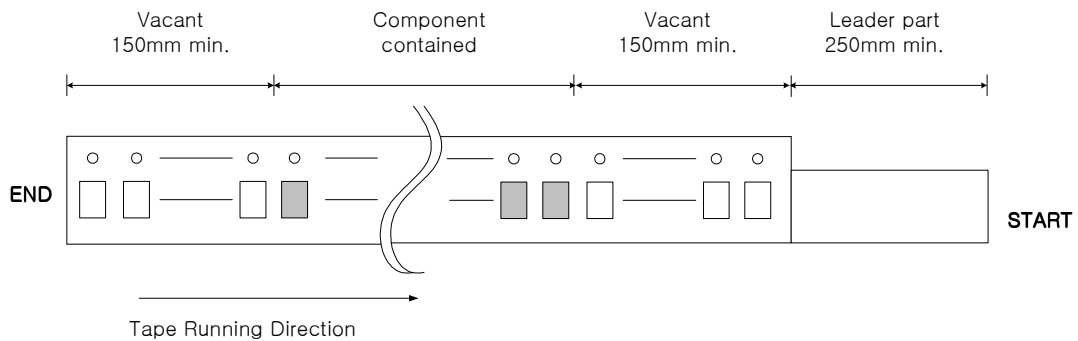



2. Tensile strength of carrier tape

4.4N/mm width

3. Top cover tape adhesion

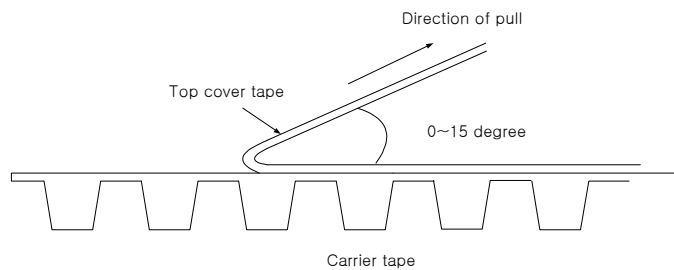
- 1) pull off angle : 0~15°
- 2) speed : 300mm/min
- 3) force : 20~70g



	ITF Co., Ltd. 102-901, Bucheon Technopark 364, Samjeong-Dong, Ojeong-Gu, Bucheon-City, Gyeonggi-Do, Korea 421-809	Part No.	F9201	
		Rev. Date	2012-12-14	
		Rev.	NRNL02-AS01	6/7

SAW Bandpass Filter 920 MHz



Carrier Tape Dimensions [unit : mm]

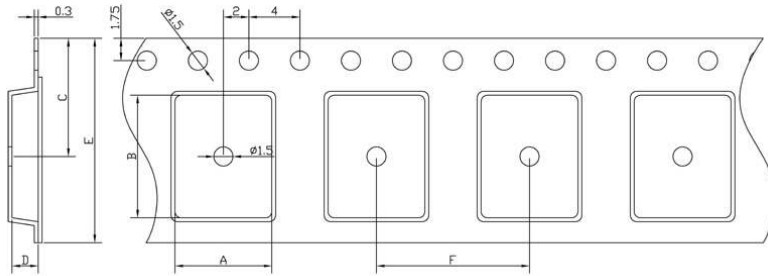

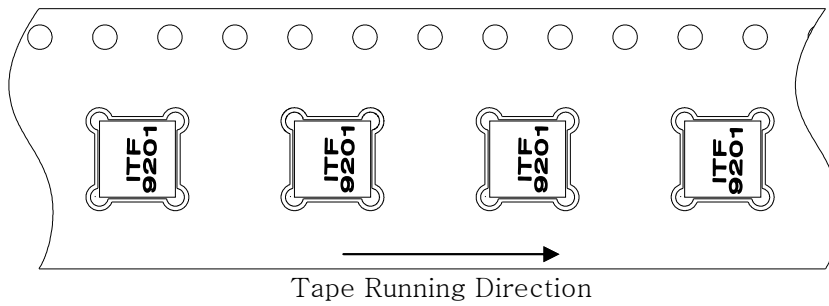

A	4.30 ± 0.1
B	4.30 ± 0.1
C	7.25 ± 0.1
D	1.70 ± 0.1
E	12.00 ± 0.1
F	8.00 ± 0.1

Part Direction

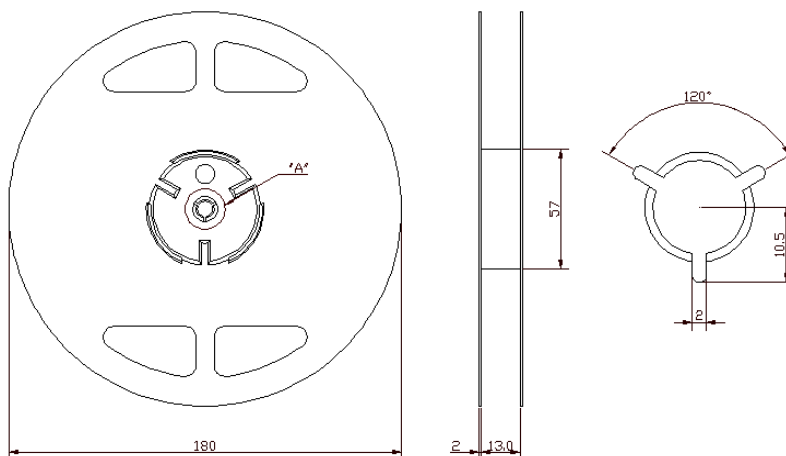

Reel Dimensions [unit : mm]



	ITF Co., Ltd. 102-901, Bucheon Technopark 364, Samjeong-Dong, Ojeong-Gu, Bucheon-City, Gyeonggi-Do, Korea 421-809	Part No.	F9201	
		Rev. Date	2012-12-14	
		Rev.	NRNL02-AS01	7/7