

SAW Bandpass Filter F8721



Features

- RF bandpass filter for 2G Repeater
- Usable Bandwidth 15MHz
- No matching single-ended operation
- Ceramic Surface Mounted Device Package (3.0 mm × 3.0 mm)
- RoHS Compliant

Package Dimension

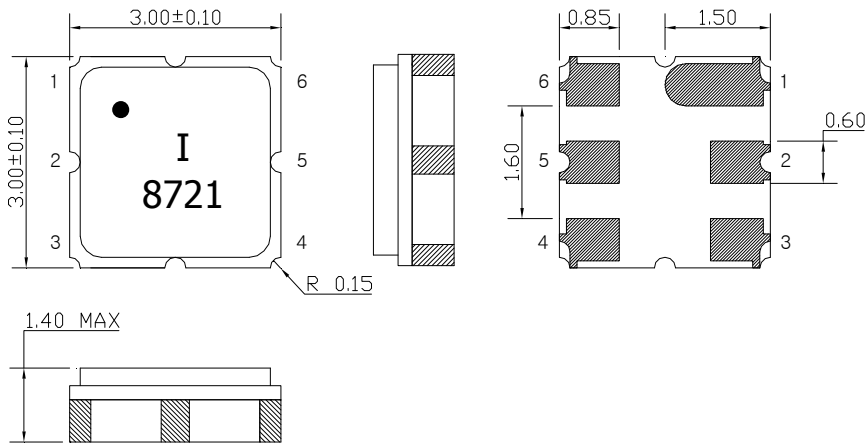

Dimensions shown are nominal in millimeters

Body : Al₂O₃ Ceramic

Lid : Kovar, Ni Plated

Terminations : Au plating 0.3 ~ 1.0 um, Over a 1.27 ~ 8.89 um
Ni Plating

Pin Configurations	
2	Input
5	Output
1, 3, 4, 6	Case ground

Maximum Ratings

Parameters	Unit	Minimum	Typical	Maximum
Operating Temperature Range	℃	-30	25	85
Storage Temperature Range	℃	-40	-	85
Power Handling Capability	dBm	-	-	10

Electrostatics Sensitive Device (ESD)

	ITF Co., Ltd. 102-901, Bucheon Technopark 364, Samjeong-Dong, Ojeong-Gu, Bucheon-City, Gyeonggi-Do, Korea 421-809	Part No.	F8721	
		Rev. Date	2014-03-19	
		Rev.	NC9012-AS02	1/7

SAW Bandpass Filter F8721



Specifications

Fo = 872.5 MHz

	Minimum	Typical	Maximum	Unit
Center Frequency (Fc)	-	872.5	-	MHz
Insertion Loss (In Fc ± 7.5 MHz)	-	2.7	3.5	dB
Amplitude Ripple (In Fc ± 7.5 MHz)	-	0.7	1.5	dB
VSWR (In Fc ± 7.5 MHz)	-	1.5	2.0	
Relative Attenuation				
10.0MHz ~ 820.0MHz	40	45	-	dB
820.0MHz ~ 835.0MHz	35	40	-	
912.0MHz ~ 927.0MHz	25	32	-	
927.0MHz ~ 972.0MHz	35	40	-	
972.0MHz ~ 1300.0MHz	40	45	-	
Input/Output Impedance		50		Ohm

Notes :

- 1) All specifications are based on the matching schematic shown below
- 2) All specifications are measured by Agilent Network analyzer and full 2 port calibration at room temperature
- 3) All attenuation measurements are measured relative to insertion loss

 Integrated Technology Future	ITF Co., Ltd. 102-901, Bucheon Technopark 364, Samjeong-Dong, Ojeong-Gu, Bucheon-City, Gyeonggi-Do, Korea 421-809	Part No.	F8721	
		Rev. Date	2014-03-19	
		Rev.	NC9012-AS02	2/7

SAW Bandpass Filter F8721



Matching Schematic

(Actual matching values may vary due to PCB layout and parasitics)

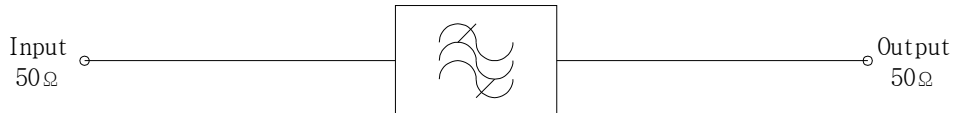

Marking Configuration

●¹⁾
I²⁾
8721³⁾

1) Pad Number 1 Index

2) Manufacturer name

3) Marking Number

* Ink or Laser Marking available

	ITF Co., Ltd. 102-901, Bucheon Technopark 364, Samjeong-Dong, Ojeong-Gu, Bucheon-City, Gyeonggi-Do, Korea 421-809	Part No.	F8721	
		Rev. Date	2014-03-19	
		Rev.	NC9012-AS02	3/7

SAW Bandpass Filter F8721



Typical Performance (at +25°C)

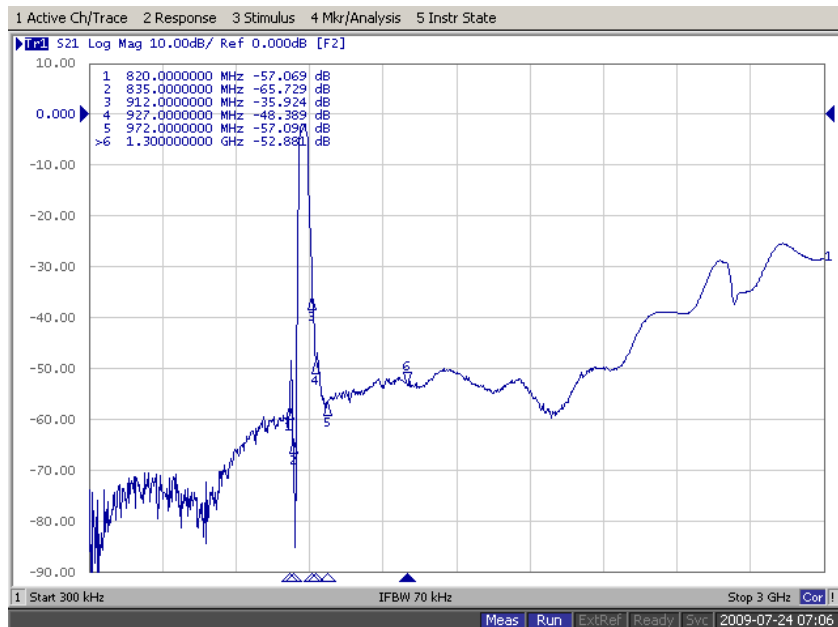
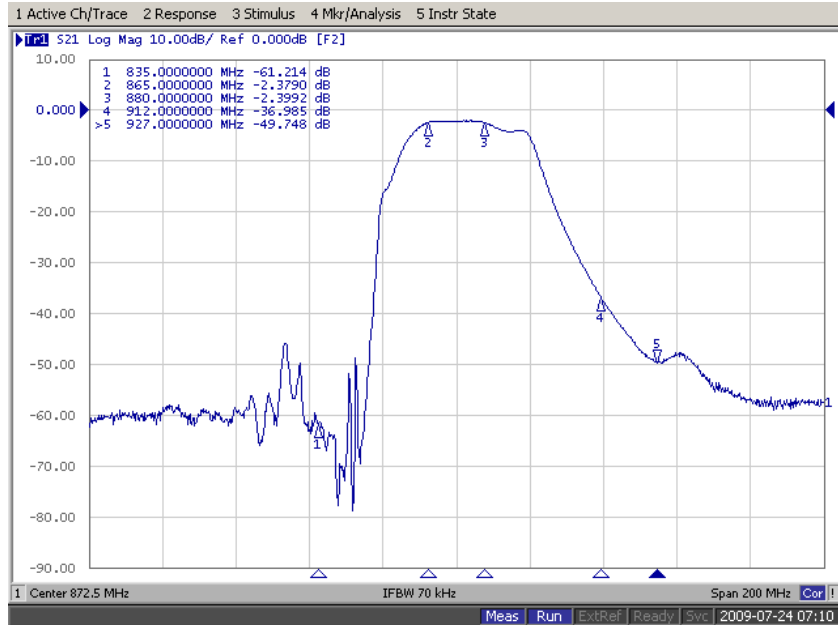

ITF Co., Ltd.
 102-901, Bucheon Technopark 364,
 Samjeong-Dong, Ojeong-Gu, Bucheon-City,
 Gyeonggi-Do, Korea 421-809

Part No.	F8721	
Rev. Date	2014-03-19	
Rev.	NC9012-AS02	4/7

SAW Bandpass Filter F8721

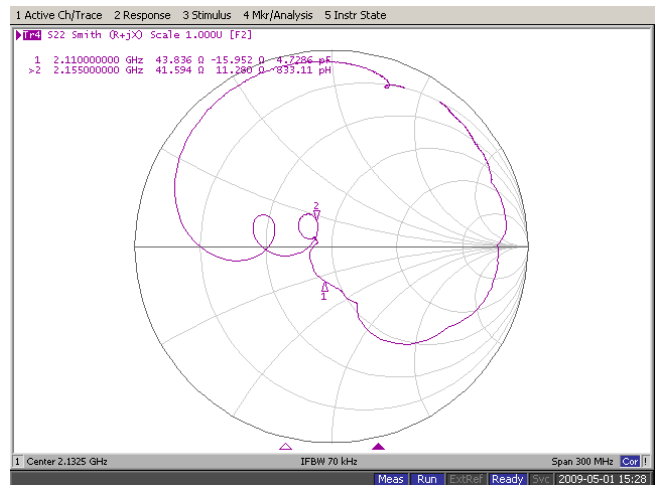
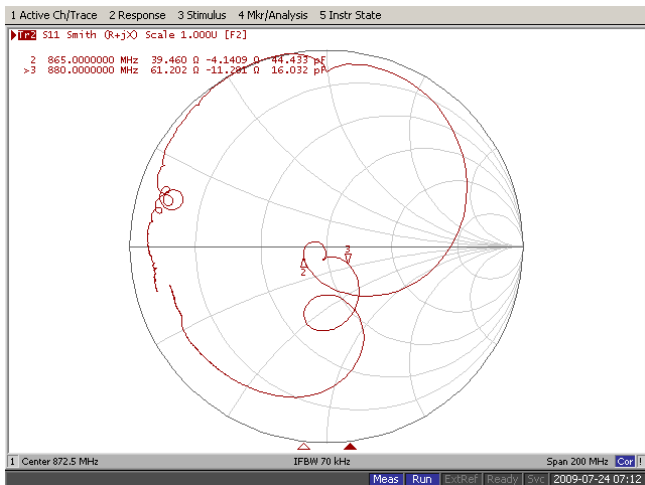
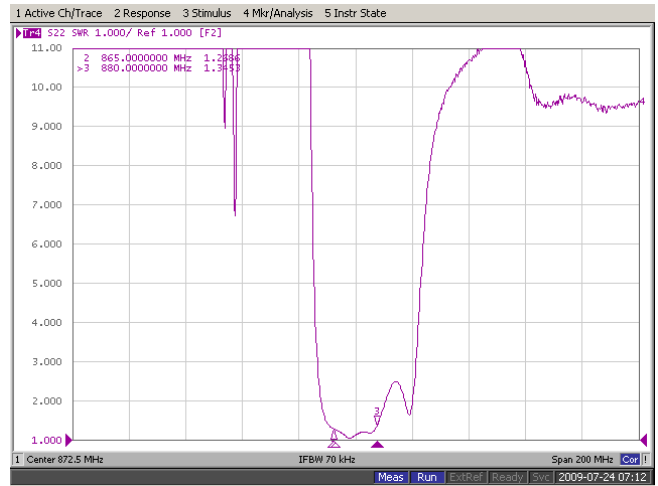
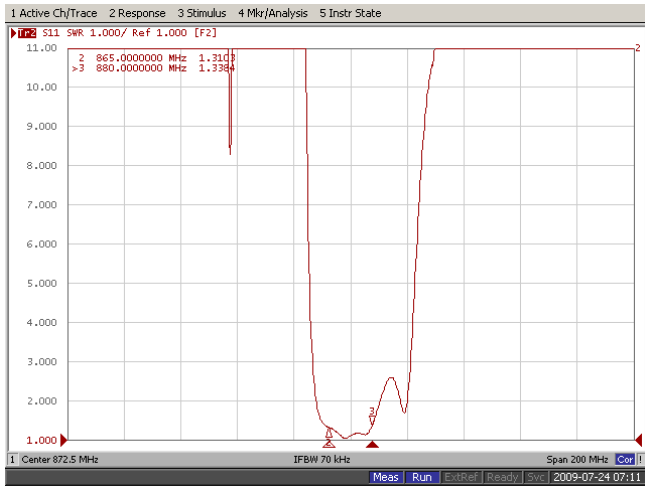

	ITF Co., Ltd. 102-901, Bucheon Technopark 364, Samjeong-Dong, Ojeong-Gu, Bucheon-City, Gyeonggi-Do, Korea 421-809	Part No. F8721	
		Rev. Date 2014-03-19	
		Rev.	NC9012-AS02

SAW Bandpass Filter F8721



Packing Specification

1. Reeling Quantity : 3000 pcs / 13" reel (or 1000 pcs / 7" reel)
2. Taping Structure : The tape shall be wound around the reel in the direction shown below.

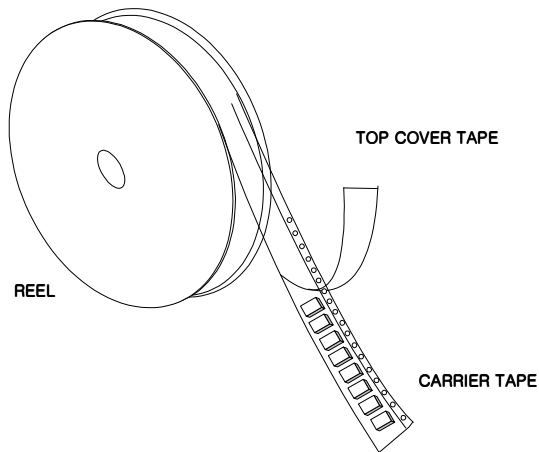

Tape Specification

1. Leader part and vacant position specification

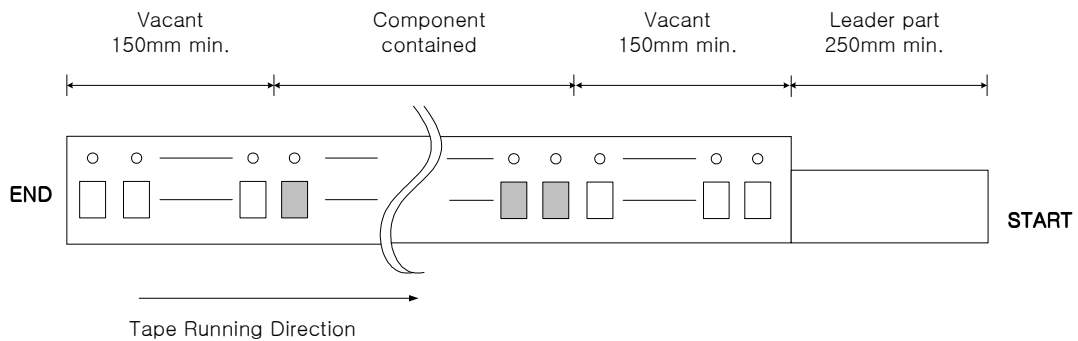

2. Tensile strength of carrier tape

4.4N/mm width

3. Top cover tape adhesion

- 1) pull off angle : 0~15°
- 2) speed : 300mm/min
- 3) force : 20~70g

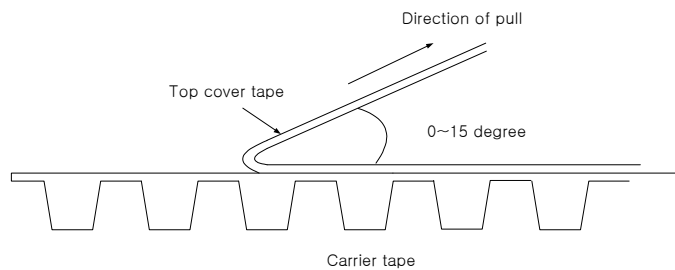

	ITF Co., Ltd. 102-901, Bucheon Technopark 364, Samjeong-Dong, Ojeong-Gu, Bucheon-City, Gyeonggi-Do, Korea 421-809	Part No.	F8721	
		Rev. Date	2014-03-19	
		Rev.	NC9012-AS02	6/7

