

SAW Bandpass Filter F1G92



Features

- W-CDMA applications
- Usable bandwidth of 60 MHz
- No impedance matching require for operation at 50 Ω
- Ceramic Surface Mounted Device Package (3.0 mm * 3.0 mm)
- Single-ended Operation
- RoHS Compliant

Package Dimensions

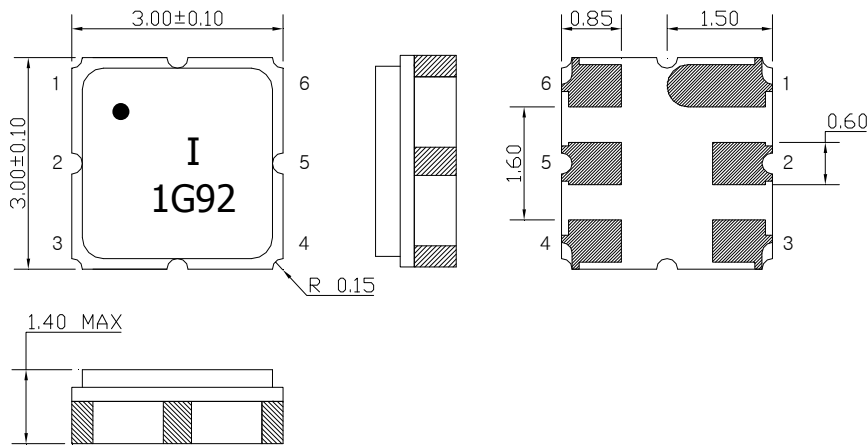

Dimensions shown are nominal in millimeters

Body : Al₂O₃ Ceramic

Lid : Kovar, Ni Plated

Terminations : Au plating 0.3 ~ 1.0 um, Over a 1.27 ~ 8.89 um
Ni Plating

Pin Configurations

2	Input
5	Output
1, 3, 4, 6	Case ground

Maximum Ratings

Parameters	Unit	Minimum	Typical	Maximum
Operating Temperature Range	℃	-30	25	85
Storage Temperature Range	℃	-40	-	85
Power Handling Capability	dBm	-	-	13

Electrostatics Sensitive Device (ESD)

	ITF Co., Ltd. 102-901, Bucheon Technopark 364, Samjeong-Dong, Ojeong-Gu, Bucheon-City, Gyeonggi-Do, Korea 421-809	Part No.	F1G92	
		Rev. Date	2014-03-19	
		Rev.	NC6001-AS04	1/7

SAW Bandpass Filter F1G92



Specifications

	Minimum	Typical	Maximum	Unit
Center Frequency (Fc)	-	1950.0	-	MHz
Insertion Loss (In Fc +/- 30.0 MHz)	-	2.8	4.0	dB
Amplitude Ripple (In Fc +/- 30.0 MHz)	-	1.4	2.4	dBp-p
VSWR (In Fc +/- 30.0 MHz)	-	1.8	2.4	
Relative Attenuation				
0.3 MHz ~ 1840.0 MHz	20.0	32.0	-	dB
1850.0 MHz ~ 1900.0 MHz	10.0	21.0	-	
2000.0 MHz ~ 2030.0 MHz	4.5	10.0	-	
2030.0 MHz ~ 2060.0 MHz	20.0	47.0	-	
2060.0 MHz ~ 3000.0 MHz	22.0	29.0	-	
Temperature Range (Operational)	-30	25	85	°C
Input RF Power (In Fc +/- 30.0 MHz)			13	dBm
Input/Output Impedance		50		Ohms

Notes :

- 1) All specifications are based on the matching schematic shown below, measured by Agilent Network analyzer and full 2 port calibration.
- 2) Electrical margin has been built into the design to account for the variations due to temperature drift and manufacturing tolerances
- 3) All attenuation measurements are measured relative to insertion loss

 Integrated Technology Future	ITF Co., Ltd. 102-901, Bucheon Technopark 364, Samjeong-Dong, Ojeong-Gu, Bucheon-City, Gyeonggi-Do, Korea 421-809	Part No.	F1G92	
		Rev. Date	2014-03-19	
		Rev.	NC6001-AS04	2/7

SAW Bandpass Filter F1G92



Matching Schematic

(Actual matching values may vary due to PCB layout and parasitics)

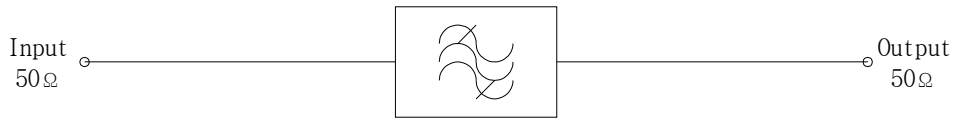

Marking Configuration

- ¹⁾
I²⁾
1G92³⁾

- 1) Pad Number 1 Index
- 2) Manufacturer name
- 3) Marking Number

* Ink or Laser Marking available

 Integrated Technology Future	ITF Co., Ltd. 102-901, Bucheon Technopark 364, Samjeong-Dong, Ojeong-Gu, Bucheon-City, Gyeonggi-Do, Korea 421-809	Part No.	F1G92	
		Rev. Date	2014-03-19	
		Rev.	NC6001-AS04	3/7

SAW Bandpass Filter F1G92



Typical Performance (at 25°C)

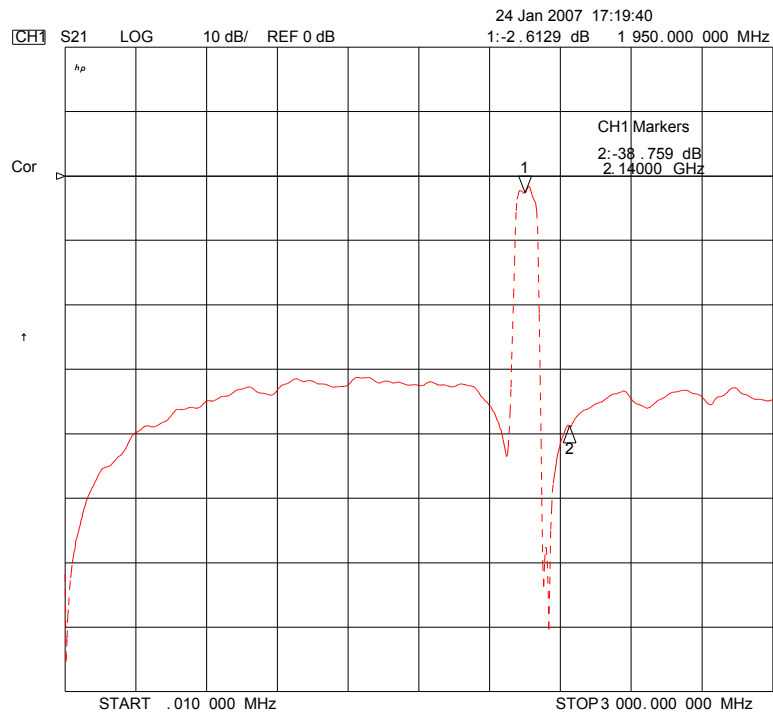
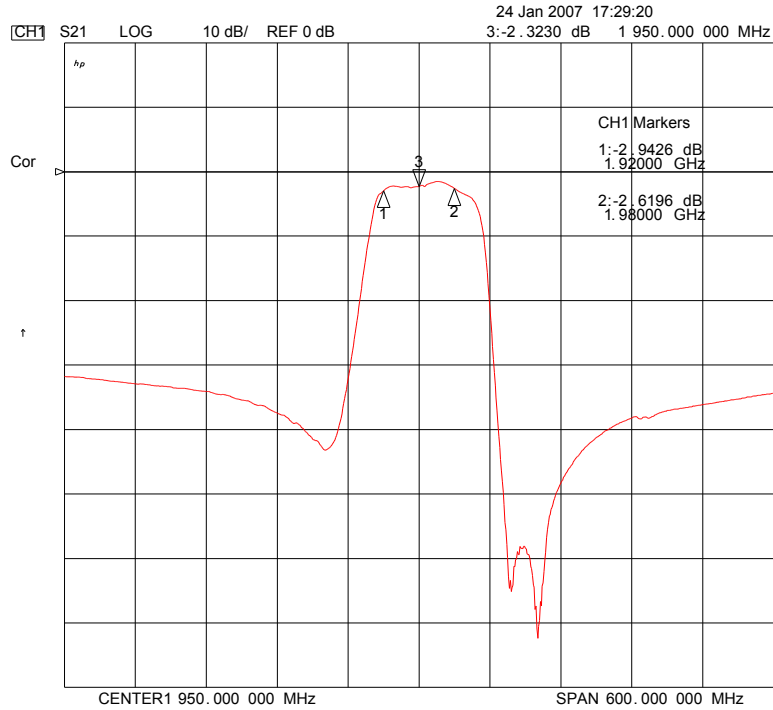

	ITF Co., Ltd. 102-901, Bucheon Technopark 364, Samjeong-Dong, Ojeong-Gu, Bucheon-City, Gyeonggi-Do, Korea 421-809	Part No.	F1G92	
		Rev. Date	2014-03-19	
		Rev.	NC6001-AS04	4/7

SAW Bandpass Filter F1G92



Input / Output VSWR Charts

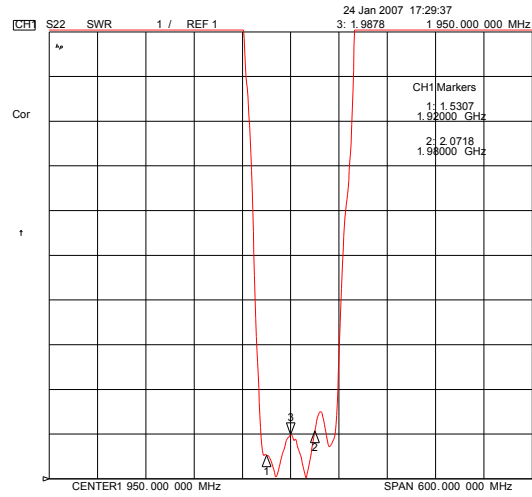
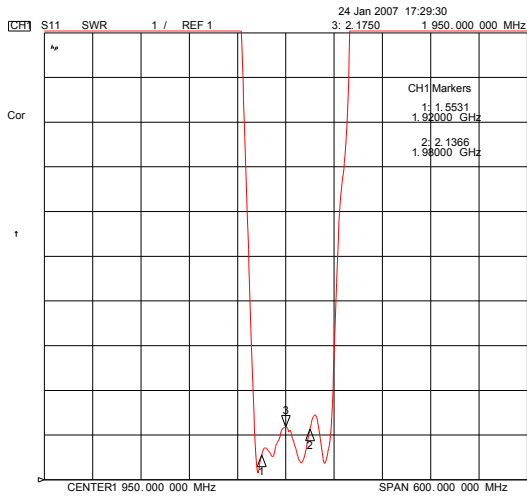

Input / Output Smith Charts

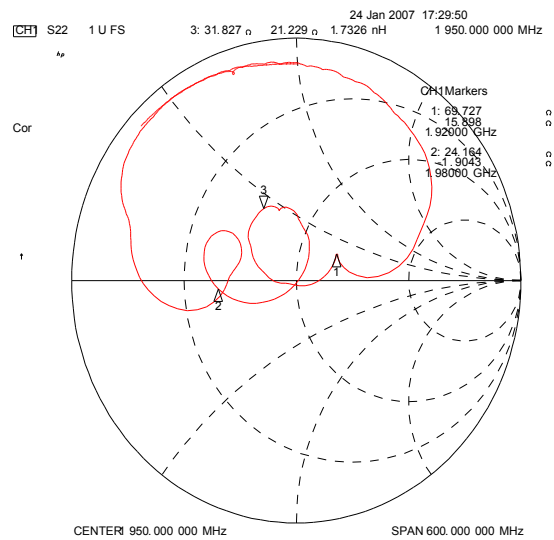
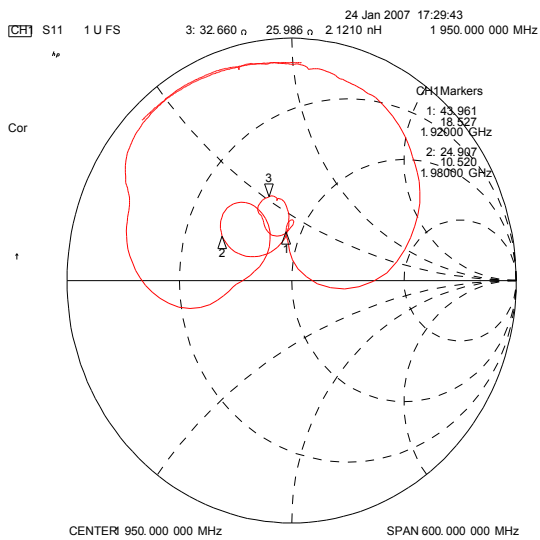

	ITF Co., Ltd. 102-901, Bucheon Technopark 364, Samjeong-Dong, Ojeong-Gu, Bucheon-City, Gyeonggi-Do, Korea 421-809	Part No.	F1G92	
		Rev. Date	2014-03-19	
		Rev.	NC6001-AS04	5/7

Packing Specification

1. Reeling Quantity : 3000 pcs / 13" reel (or 1000 pcs / 7" reel)
2. Taping Structure : The tape shall be wound around the reel in the direction shown below.

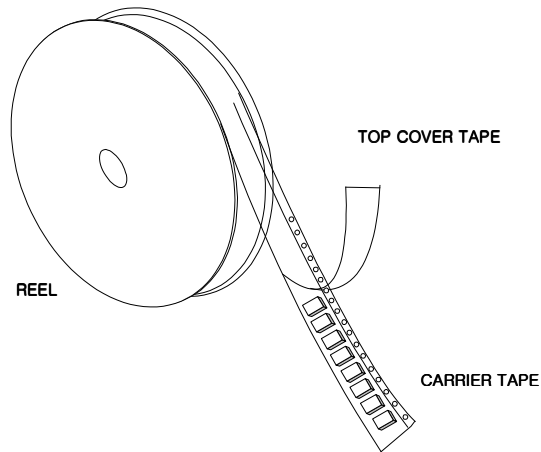

Tape Specification

1. Leader part and vacant position specification

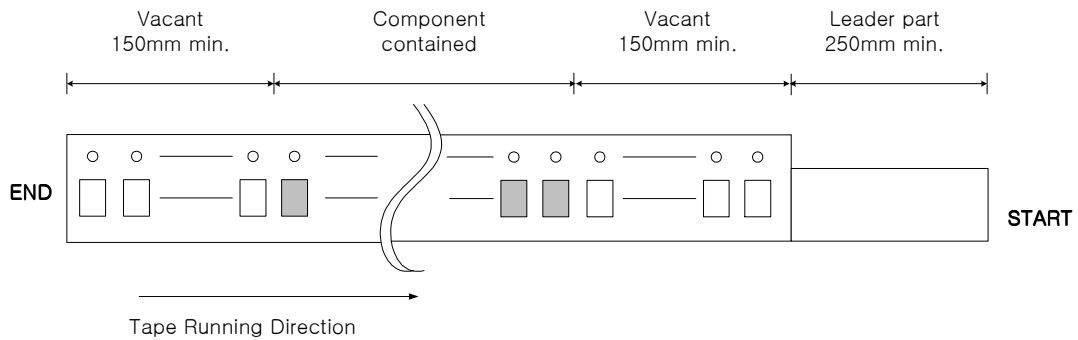

2. Tensile strength of carrier tape

4.4N/mm width

3. Top cover tape adhesion

- 1) pull off angle : 0~15°
- 2) speed : 300mm/min
- 3) force : 20~70g

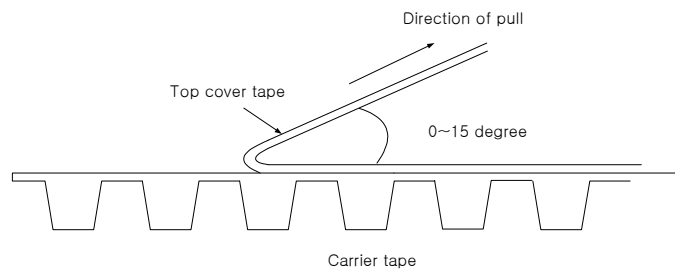

	ITF Co., Ltd. 102-901, Bucheon Technopark 364, Samjeong-Dong, Ojeong-Gu, Bucheon-City, Gyeonggi-Do, Korea 421-809	Part No.	F1G92	
		Rev. Date	2014-03-19	
		Rev.	NC6001-AS04	6/7

SAW Bandpass Filter F1G92



Carrier Tape Dimensions [unit : mm]

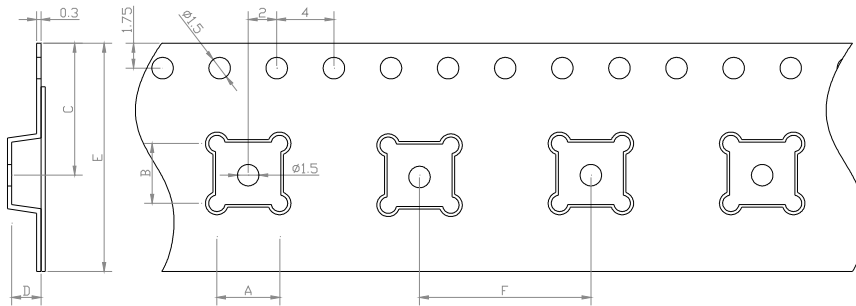

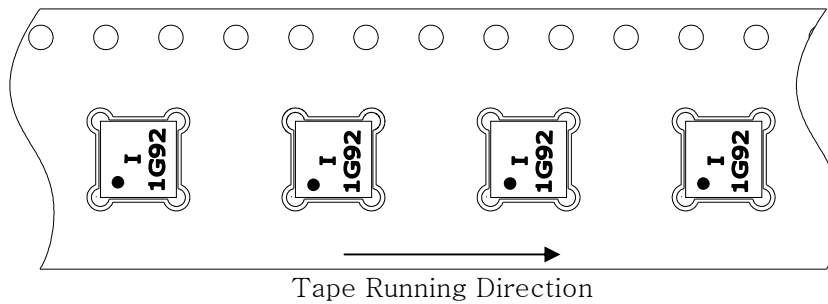

A	3.40 ± 0.1
B	3.40 ± 0.1
C	7.25 ± 0.1
D	1.70 ± 0.1
E	12.00 ± 0.1
F	8.00 ± 0.1

Part Direction

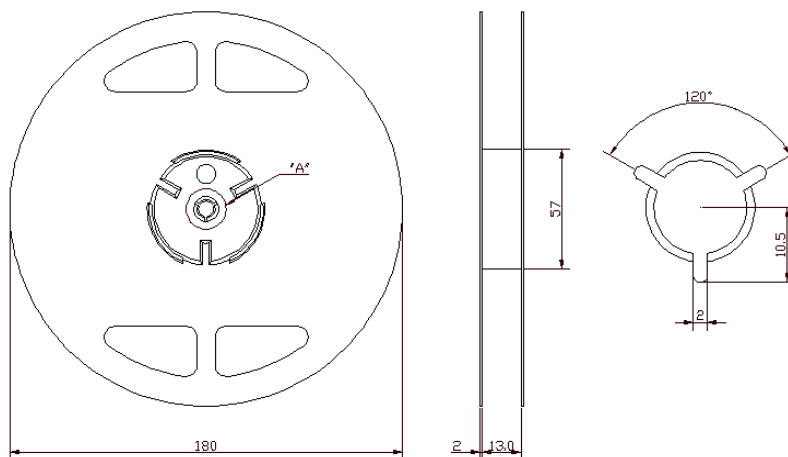

Reel Dimensions [unit : mm]



	ITF Co., Ltd. 102-901, Bucheon Technopark 364, Samjeong-Dong, Ojeong-Gu, Bucheon-City, Gyeonggi-Do, Korea 421-809	Part No.	F1G92	
		Rev. Date	2014-03-19	
		Rev.	NC6001-AS04	7/7